

**CLAYTON OFF ROAD
COR-1108102
JEEP WRANGLER DANA 44 TRUSS (2007-2017, JK)**

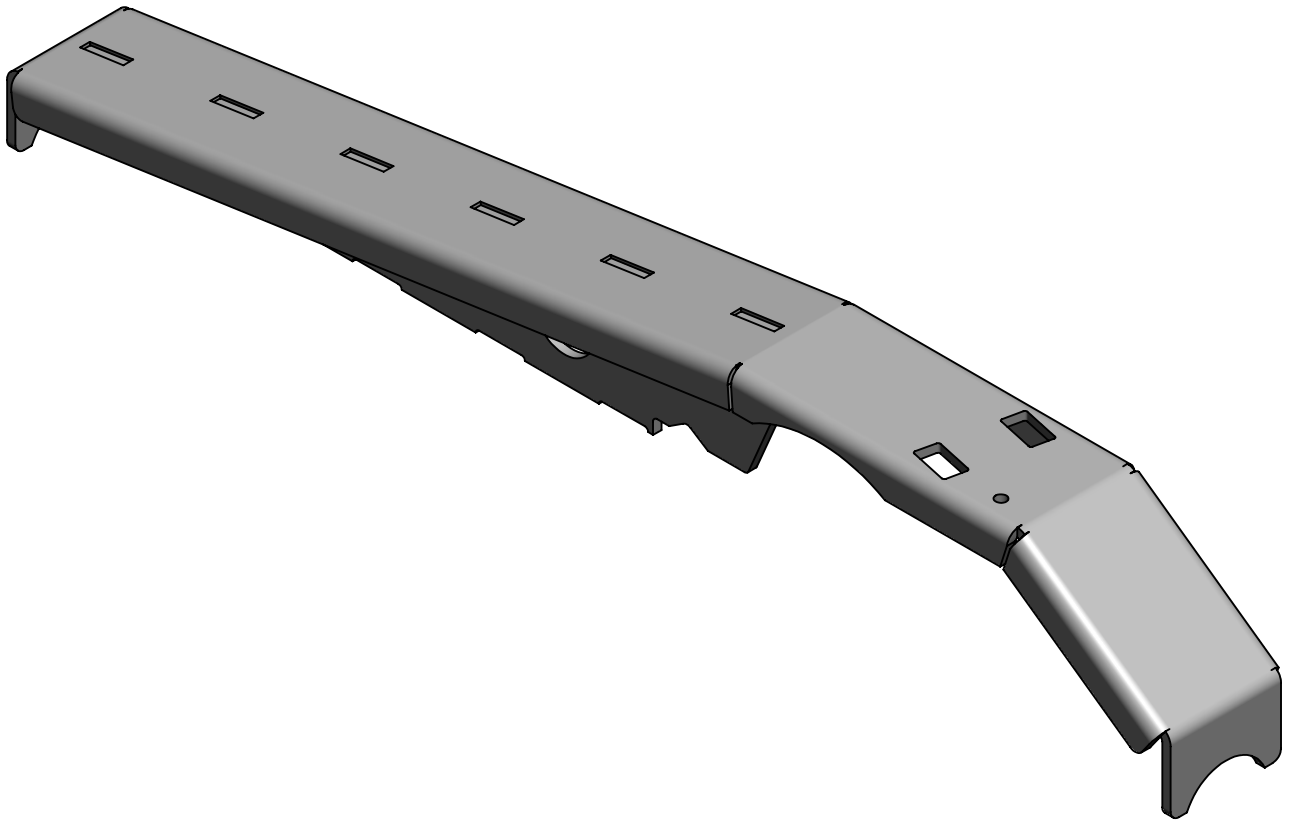

NOTES: This product may require general welding, fabrication and automotive mechanic skills. Welding should only be done by a competent welder. Clayton Off Road implies no guarantees or warranties and is not liable for improper installation. Some grinding and fitment may be required when installing this product. Every vehicle varies slightly and some fabrication may be required. For more information please visit our website.

Refer to picture below.

Step 1: Remove axle from vehicle.

Step 2: Remove passenger side upper control arm mount.

Step 3: Remove drive side upper control arm bushing.

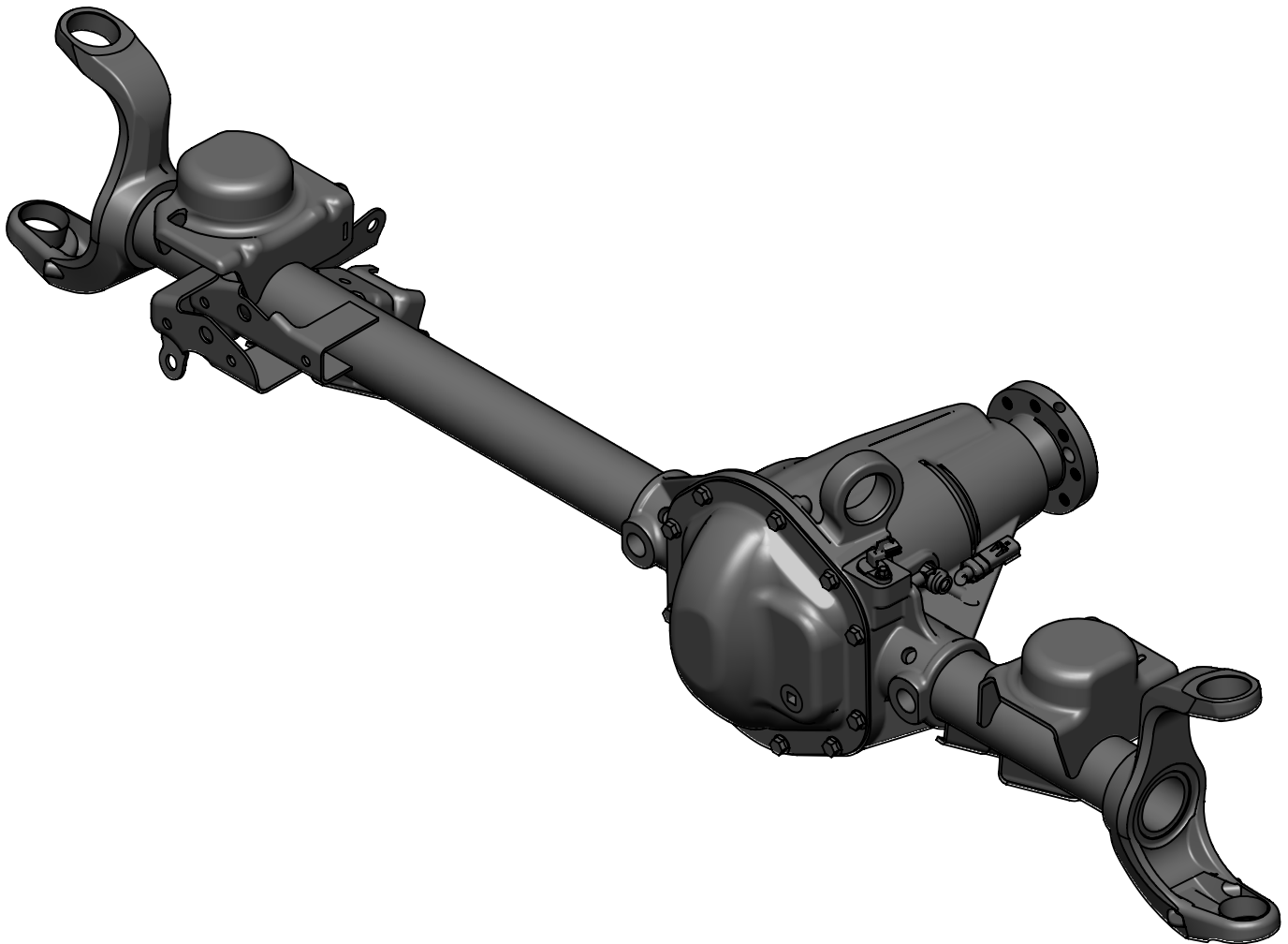

Refer to picture below.

Step 4: Trim driver side upper control arm mount so that you have 2 post that fit into the 2 cut outs in the top of the truss about an 1/8" below the top of the truss.

Step 5: Bevel the truss where the axle tube goes so it clears the welds on the spring perch.

Step 6: If you are using a Dyntrac Dana 44 or other after market axle trim the truss gusset to fit.

Step 7: Test fit the truss and gusset on the axle. It maybe necessary to clamp it down so the gusset fits tight to the axle tube.

Note: These are rough dimensions to use for trimming the mount. The 1.243" dimension is from the top of the mount to the top of the truss. The 1.917" dimension is from the locker connector surface to the top of the truss. Remember the post should be an 1/8" below the top of the truss for welding.

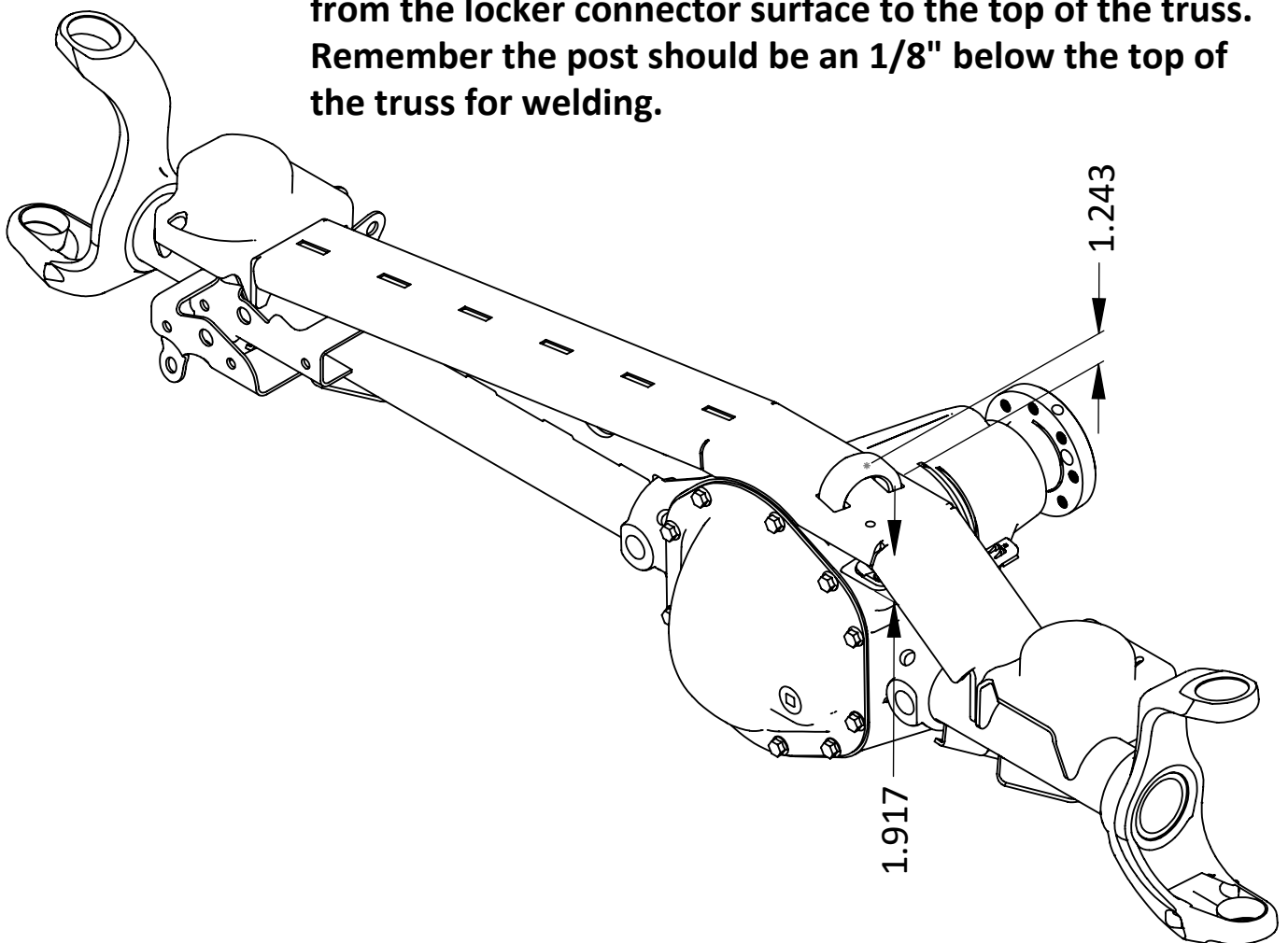

Refer to picture below.

Step 8: Weld 5 slots along gusset to axle tube on both sides.

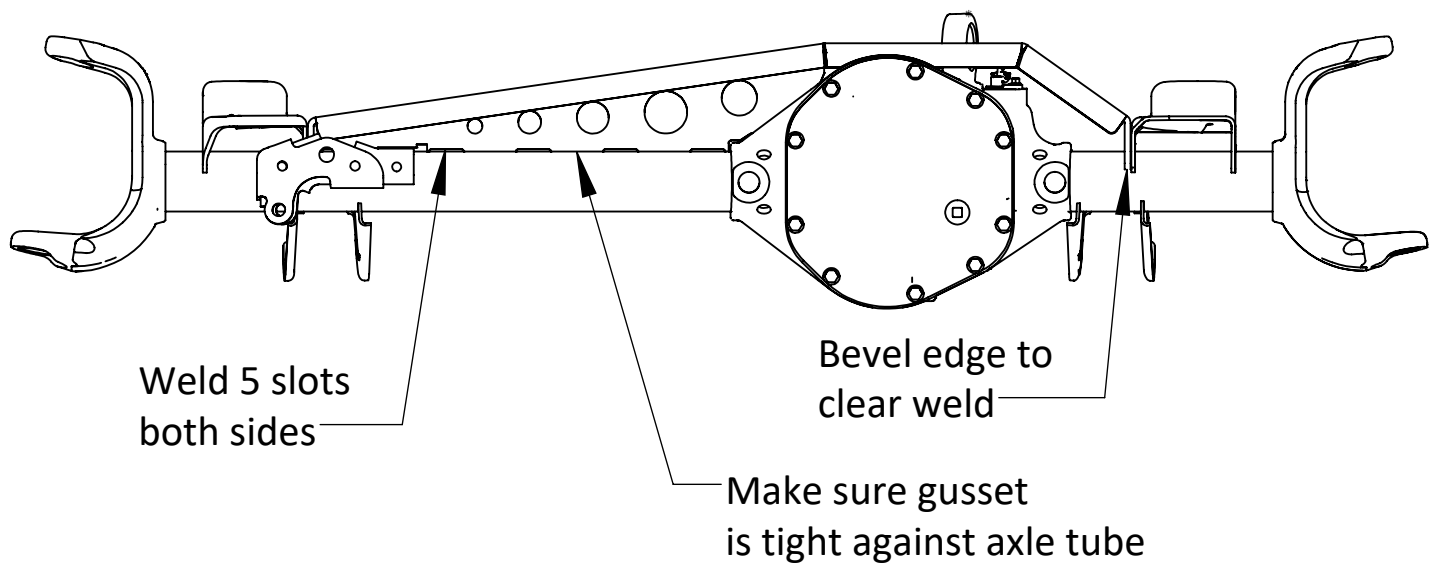

Refer to picture below.

Step 9: Weld 6 keyways.

Step 10: Weld 2 posts into cut outs.

Step 11: Weld truss to axle tubes and spring perches.

Step 12: Weld 4 corners of the truss.

Step 13: Weld optional 3 link mount part number COR-1130110 to truss on all sides inside and out.

Step 14: Paint axle.

Step 15: Install axle in vehicle.

