

**CLAYTON OFF ROAD
COR-1200020
4 LINK AXLE TRUSS BUILDER SERIES (1984-2006 TJ/LJ/XJ/ZJ)**

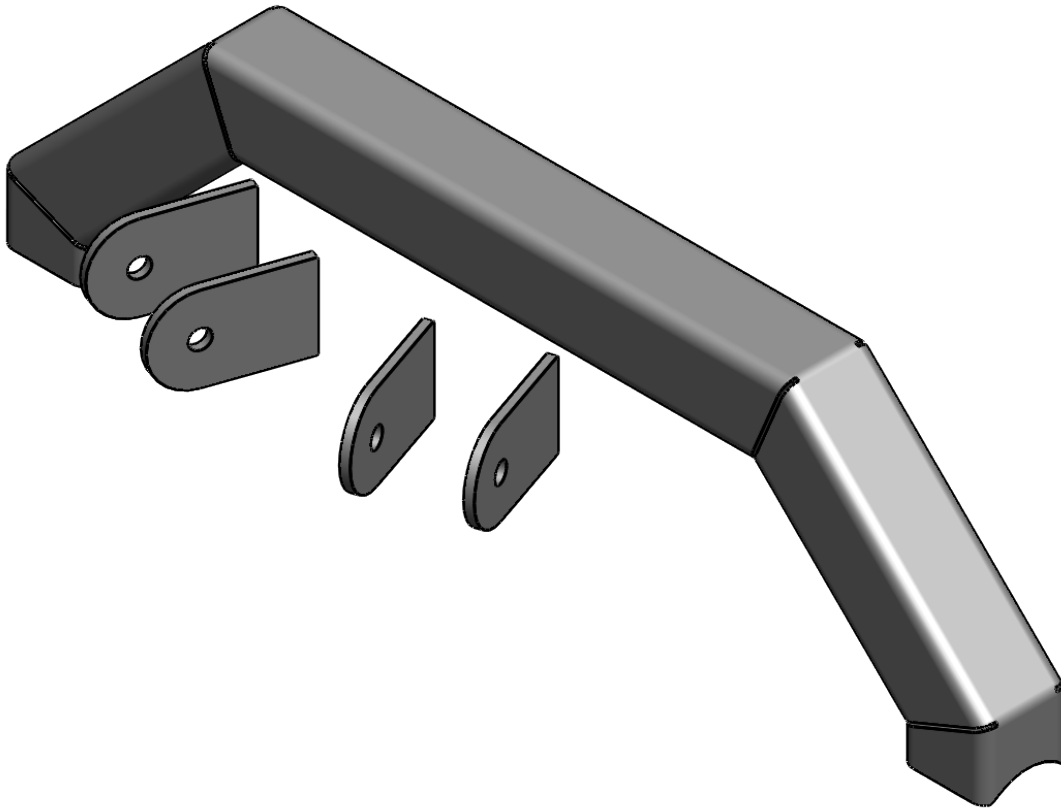

NOTES: This product may require general welding, fabrication and automotive mechanic skills. Welding should only be done by a competent welder. Clayton Off Road implies no guarantees or warranties and is not liable for improper installation. Some grinding and fitment may be required when installing this product. Every vehicle varies slightly and some fabrication may be required. For more information please visit our website.

Refer to drawing for specific vehicle for truss angle.

Step 1: Move brake lines out of the way.

Step 2: Clean any mold brackets from axle that may interfere with truss.

Step 3: Clean axle tubes for welding.

Step 4: Position axle in vehicle at ride height.

Step 5: Center axle truss on axle at proper angle.

Step 6: Tack weld four corners of truss.

Step 7: Position upper arms in vehicle.

Step 8: Modify the length of the inside tab to match control arm angle.

Step 7: Weld as indicated.

Step 8: Paint axle and truss.

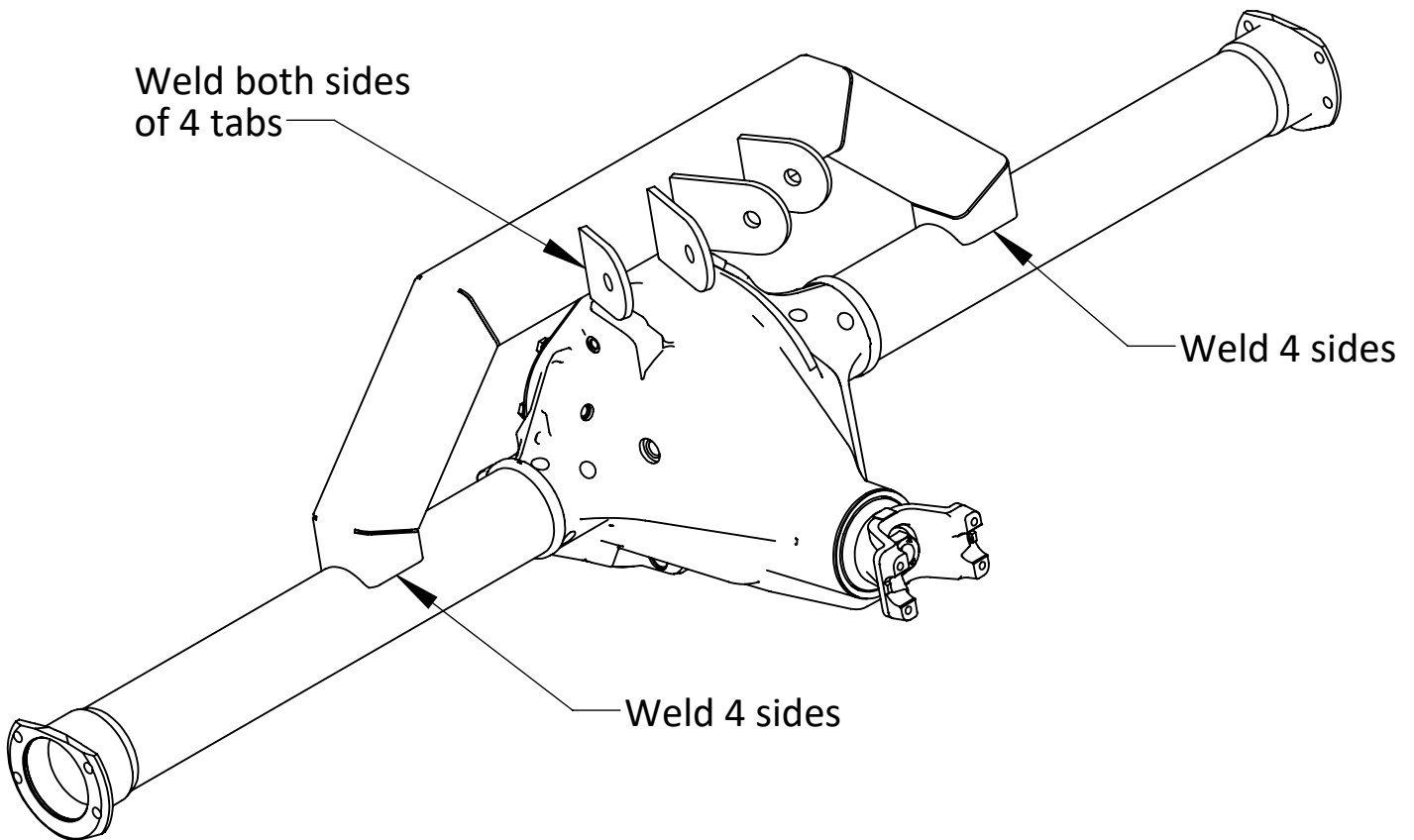

Jeep Wrangler 1997-2006 TJ

Standard setup 4" - 6" of lift.

SYE kit.

High clearance skid plate.

Approx. 23 degree pinion angle low pinion.

Approx. 18 degrees pinion angle high pinion.

Truss angle approx. 16 degrees low pinion.

Truss angle approx. 11 degrees high pinion.

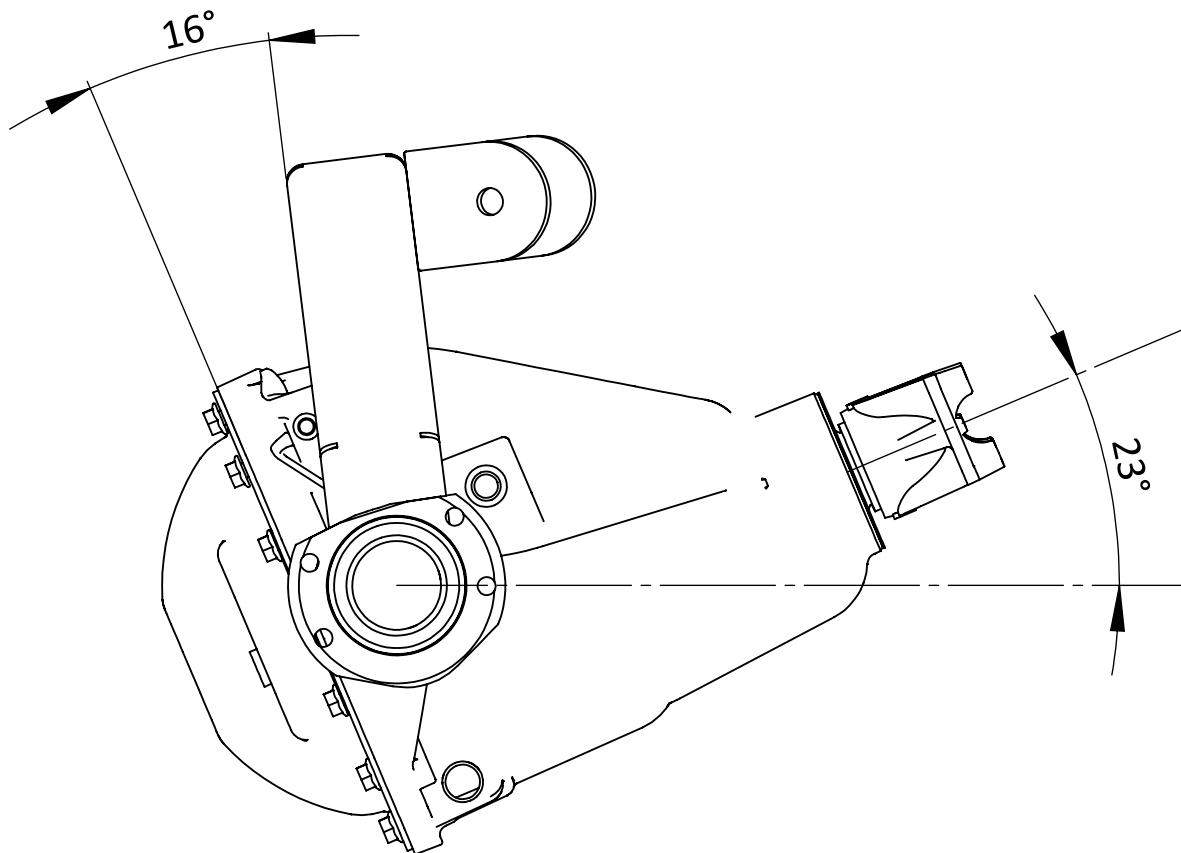

JEEP WRANGLER 2004-2006 LJ

Standard setup 4" - 6" of lift.

SYE kit.

High clearance skid plate.

Approx. 19 degree pinion angle low pinion.

Approx. 14 degrees pinion angle high pinion.

Truss angle approx. 12 degrees low pinion.

Truss angle approx. 7 degrees high pinion.

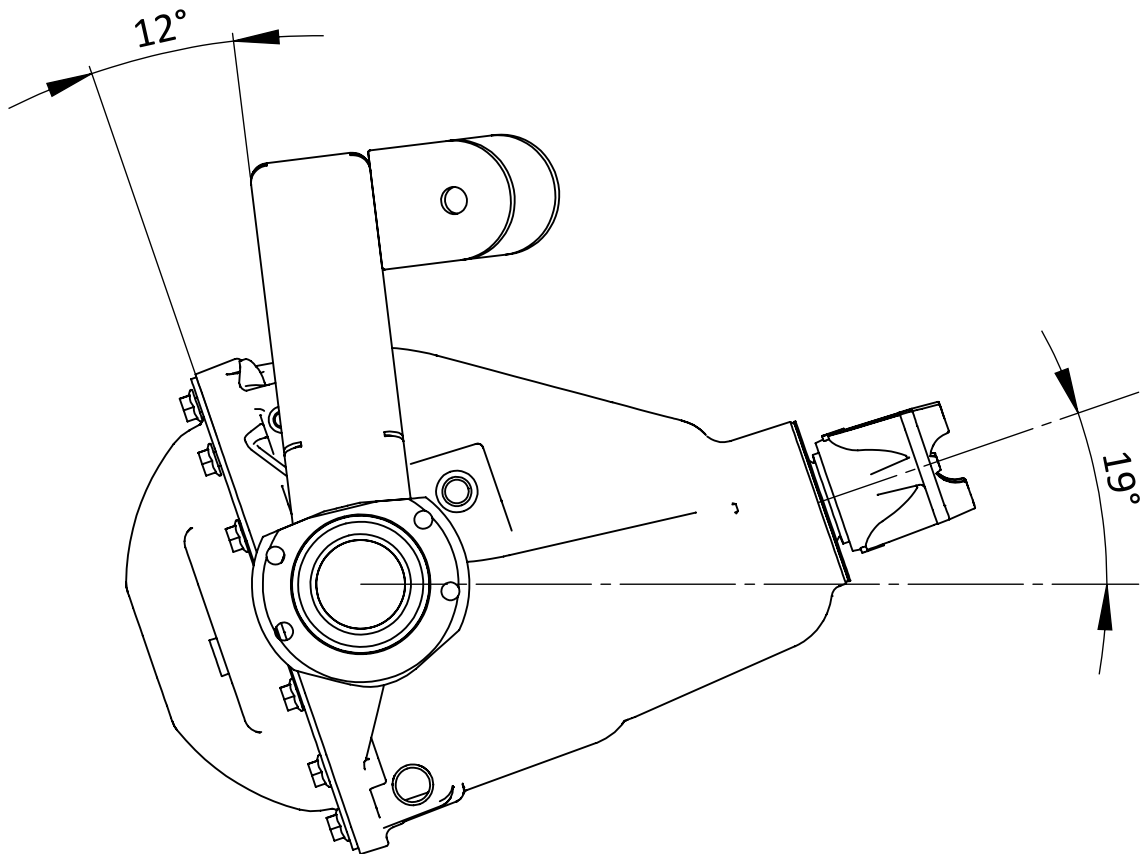

Jeep Cherokee 1984-2001 XJ

Standard setup 6" - 8" of lift.

SYE kit.

Approx. 17 degree pinion angle low pinion.

Approx. 12 degrees pinion angle high pinion.

Truss angle is parallel to differential cover face or perpendicular to pinion angle.

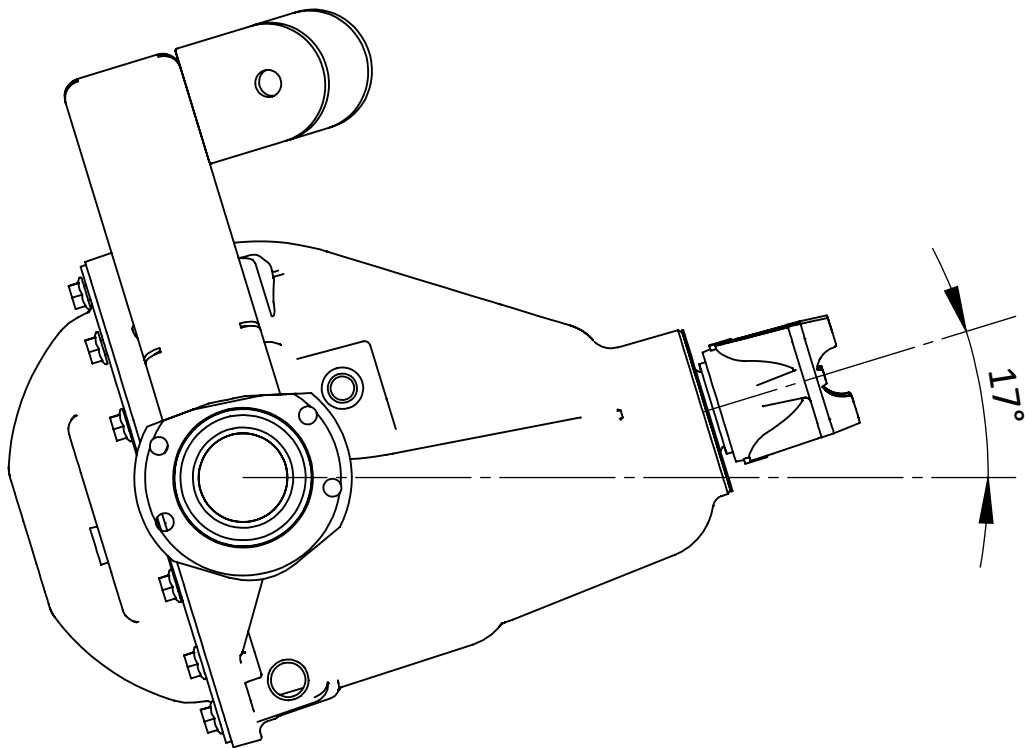

JEEP GRAND CHEROKEE 1993-1998 ZJ

Standard setup 5" - 7" of lift.

SYE kit.

Approx. 12 degree pinion angle low pinion.

Approx. 7 degrees pinion angle high pinion.

Truss angle is parallel to differential cover face or perpendicular to pinion angle.

