

**CLAYTON OFF ROAD  
COR-2204110  
JEEP GRAND CHEROKEE REAR FRAME BRACKETS (1993-1998, ZJ)**

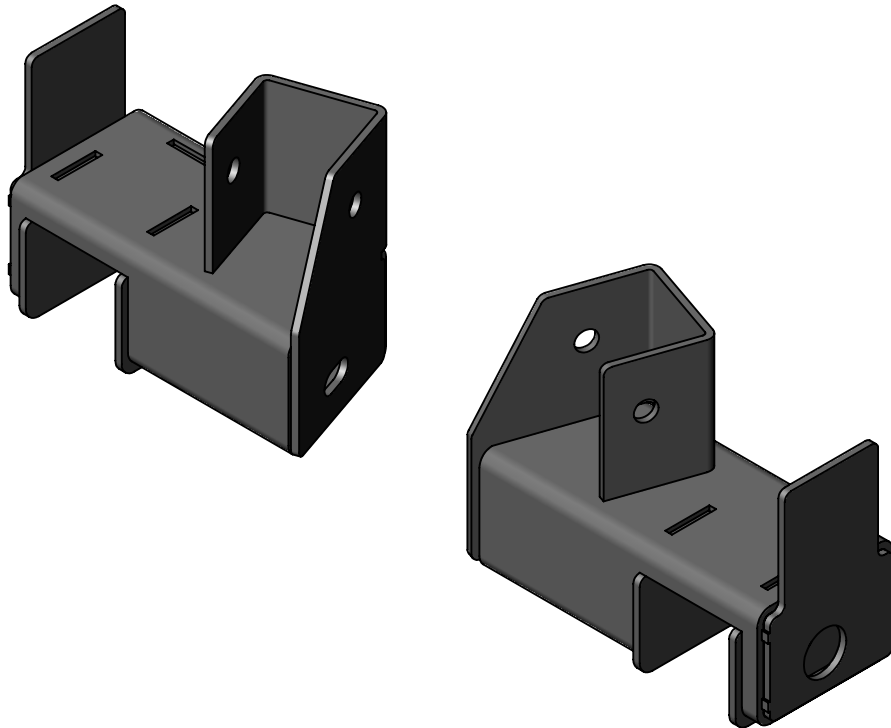

NOTES: This product requires general welding, fabrication and automotive mechanic skills. Welding should only be done by a competent welder. Clayton Off Road implies no guarantees or warranties and is not liable for improper installation. Some grinding and fitment may be required when installing this product. Every vehicle varies slightly and some fabrication may be required. For more information please visit our web site.

Refer to drawing views.

Step 1: Install part number COR-2104310 or COR-2104610 3 piece cross member.

Step 2: Clean frame for welding.

Step 3: Locate brackets according to dimensions given. Wood blocks and a bottle jack work well for holding the brackets in place.

Step 4: Check fitment of ZJ uni-body sub frame rails. Leaving about 1/8" gap is helpful during the install.

Step 5: Tack weld 4 corners of brackets.

Step 6: Weld around all 4 sides of the bracket.

Step 7: Paint frame brackets.

Note: It is possible to use these brackets without part number COR-2104310 or COR-2104610 and measure from the stock cross member. We recommend using part number COR-2204210 to reinforce the brackets.

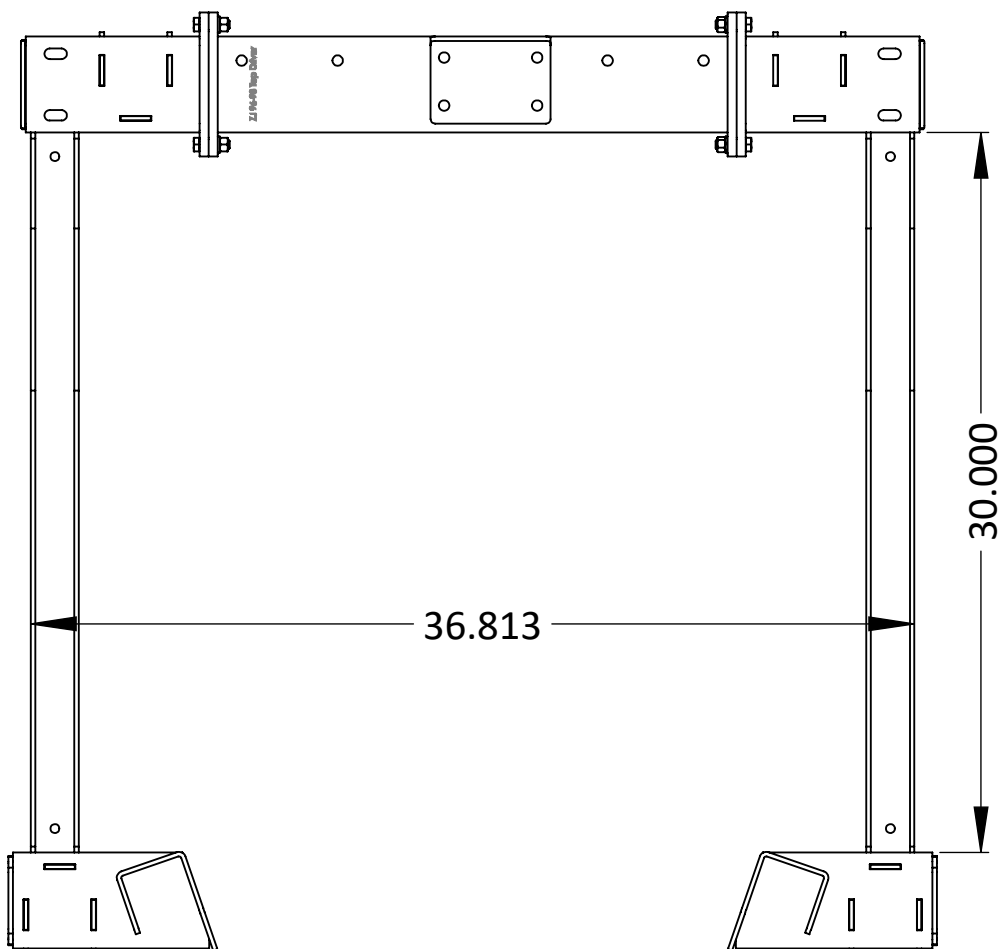

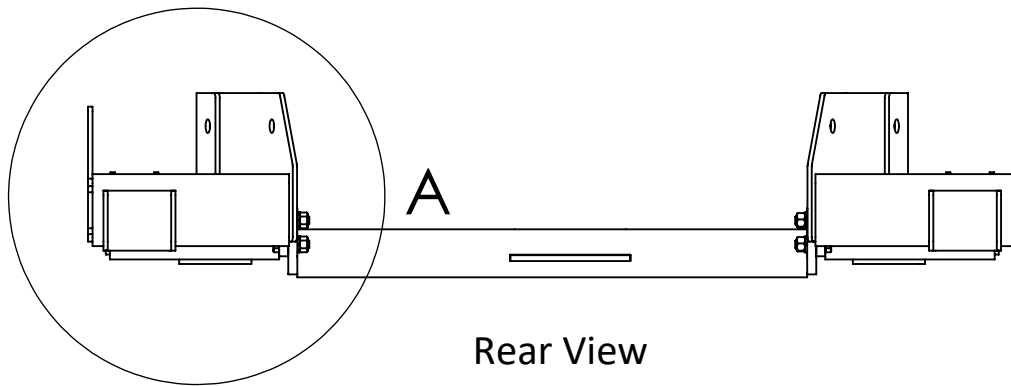

Align edge of  
bracket with frame

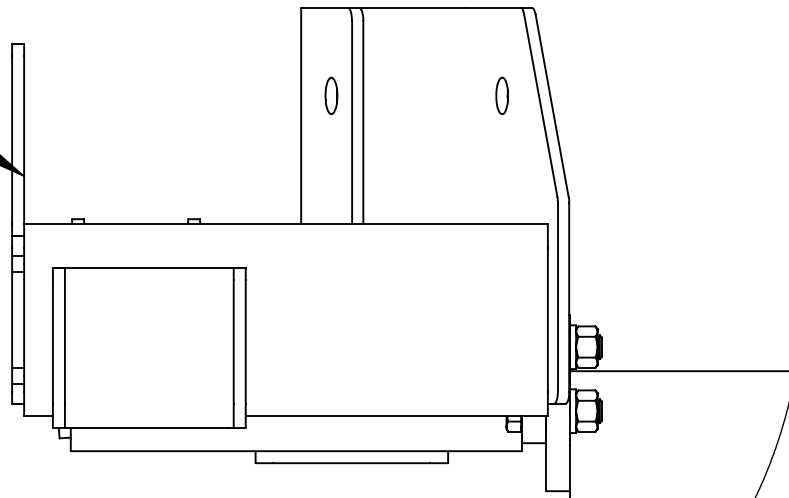

DETAIL A

SCALE 1 : 3

