

CLAYTON OFF ROAD
COR-3005040
JEEP WRANGLER 4.0" OVERLAND SHORT ARM LIFT KIT 1997-2006, (TJ/LJ)

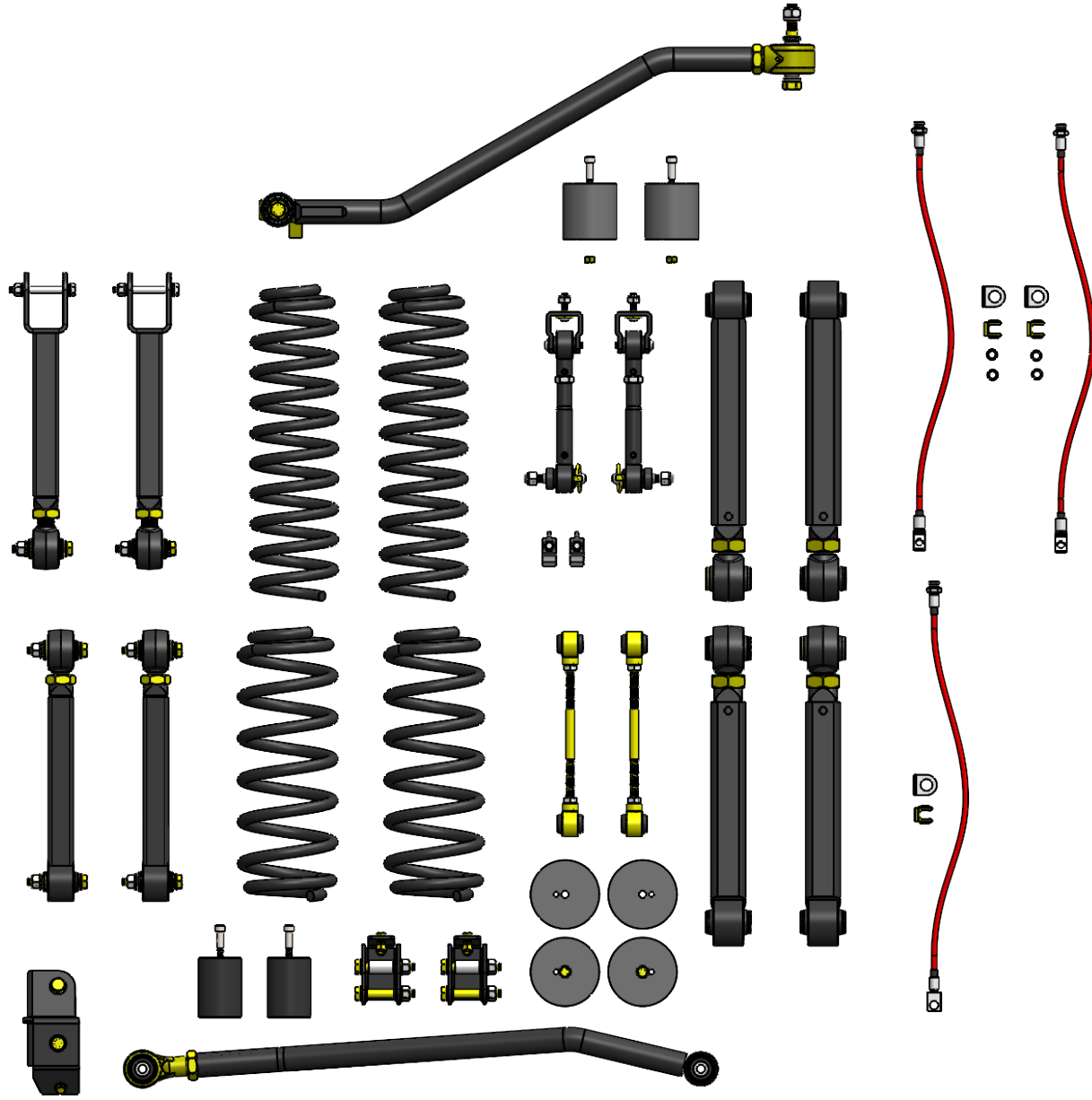

NOTES: This product may require general welding, fabrication and automotive mechanic skills. Welding should only be done by a competent welder. Clayton Off Road implies no guarantees or warranties and is not liable for improper installation. Some grinding and fitment may be required when installing this product. Every vehicle varies slightly and some fabrication may be required. For more information please visit our website.

Recommended starting lengths for track bars and control arms. These lengths can be adjusted as needed for caster angle, drive shaft angles and tire clearance. Please make sure to not exceed the maximum length of the control arms or track bars.

	TJ 4.0" Lift
Front Caster Angle	5 Degrees
Front Lower Arms	16 3/8
Front Sway Bar Links	11
Front Track Bar	32
Front Upper Arms	15 3/8
Rear Lower Arms	16 1/8
Rear Pinion Angle	17 Degrees
Rear Sway Bar Links	10 1/2
Rear Track Bar	33
Rear Upper Arms	13 3/8

Refer to individual product part number instructions.

Step 1: Position front of vehicle on jack stands or complete vehicle on lift.

Step 2: Support front axle.

Step 3: Remove front tires.

Step 4: Loosen front track bar bolts.

Step 5: Loosen front upper and lower control arm bolts.

Step 6: Remove front sway bar links.

Step 7: Remove front shocks.

Step 8: Remove old brake lines and install new brake lines on both sides.

Step 9: Unclip and disconnect all hoses and wires going to the front axle.

Step 10: Lower front axle.

Step 11: It maybe necessary to remove steering tie rod from pitman arm.

Step 12: Remove front springs.

Step 13: Remove front upper and lower control arms on one side.

Step 14: Install front lower control arm part number COR-1700100 with offset downward.

Step 15: Install front upper control arm part number COR-1700101

Step 16: Repeat steps 13 and 15 on other side.

Step 17: Remove front track bar.

Step 18: Install front track bar bracket part number COR-4500205.

Step 19: Install front bump stops part number COR-1408100.

Step 20: Install front springs part number COR-1505400. Put bump stop in spring before installing.

Step 21: Install front shocks.

Step 22: Install front sway bar links.

Step 23: Clip and connect all wires and tubes going to the front axle.

Step 24: Install front tires.

Step 25: Position rear of vehicle on jack stands or complete vehicle on lift.

Step 26: Support rear axle.

Step 27: Remove rear tires.

Step 28: Loosen rear track bar bolts.

Step 29: Loosen rear upper and lower control arm bolts.

Step 30: Remove old brake lines and install new brake lines on both sides.

Step 31: Unclip and disconnect all wires and hoses going to the rear axle.

Step 32: Remove rear shocks.

Step 33: Lower rear axle.

Step 34: Remove rear springs.

Refer to individual product part number instructions.

Step 36: Remove rear upper and lower control arms on one side.

Step 37: Install rear lower control arm part number COR-1700100 .

Step 38: Install rear upper control arm part number COR-1700102.

Step 39: Repeat steps 36 and 38 on other side.

Step 40: Remove rear track bar.

Step 41: Drill and tap lower coil bucket for part number COR-1200508.

Step 42: Install rear track bar bracket part number COR-4500500.

Step 43: Install rear track bar part number COR-4500210.

Step 44: Install rear springs part number COR-1505401. The rear bump stops part number COR-1400200 along with the upper jounce bumper should be put inside the spring first.

Step 45: Install rear shock extensions part number COR-1200510.

Step 46: Install rear shocks.

Step 47: Install rear sway bar links.

Step 48: Clip and connect all wires and hoses going to the rear axle.

Step 49: Install rear tires.

Step 50: Bleed brake lines to remove all air in the lines.

Step 51: With vehicle sitting at ride height center both front and rear axles under the vehicle by adjusting the front and rear track bars.

Step 52: In the next 2 steps it is very important to set the caster and pinion angle with a jack with the bolts at one end removed then adjust the length of the upper control arms so they are loaded up equally when the jack is removed.

Step 53: Adjust length of front upper arms to have a caster angle of 6.0 degrees. This angle should be within plus or minus 1.00 degrees.

Step 54: Adjust rear pinion angle for drive shaft alignment. I SYE kit is recommended.

Step 55: Tighten all track bar and control arm bolts.

Step 56: Tighten all track bar and control arm jam nuts.

**CLAYTON OFF ROAD
COR-1100108
JEEP STAINLESS STEEL FRONT SPRING RETAINERS (1984-2006, TJ/LJ/XJ/ZJ)**

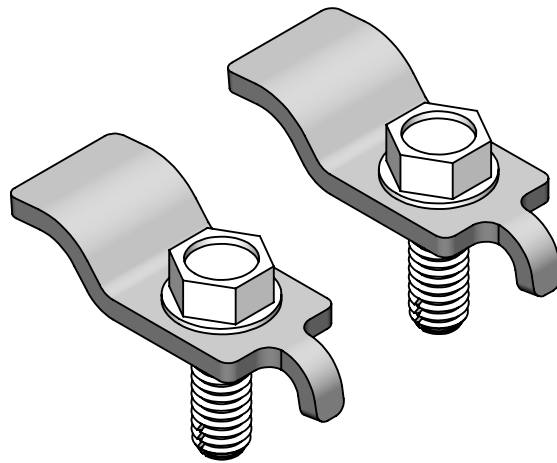

NOTES: This product may require general welding, fabrication and automotive mechanic skills. Welding should only be done by a competent welder. Clayton Off Road implies no guarantees or warranties and is not liable for improper installation. Some grinding and fitment may be required when installing this product. Every vehicle varies slightly and some fabrication may be required. For more information please visit our website.

Refer to picture below.

Step 1: Remove enough weight from the front of the vehicle to create a gap in the bottom two coils of the spring.

Step 2: Remove old spring retainers if installed.

Step 3: Install spring retainers over bottom coil of spring.

Step 4: Make sure alignment tang is aligned with hole in spring perch.

Step 5: Install 5/16" self tapping screw into spring perch. (Be sure not to strip)

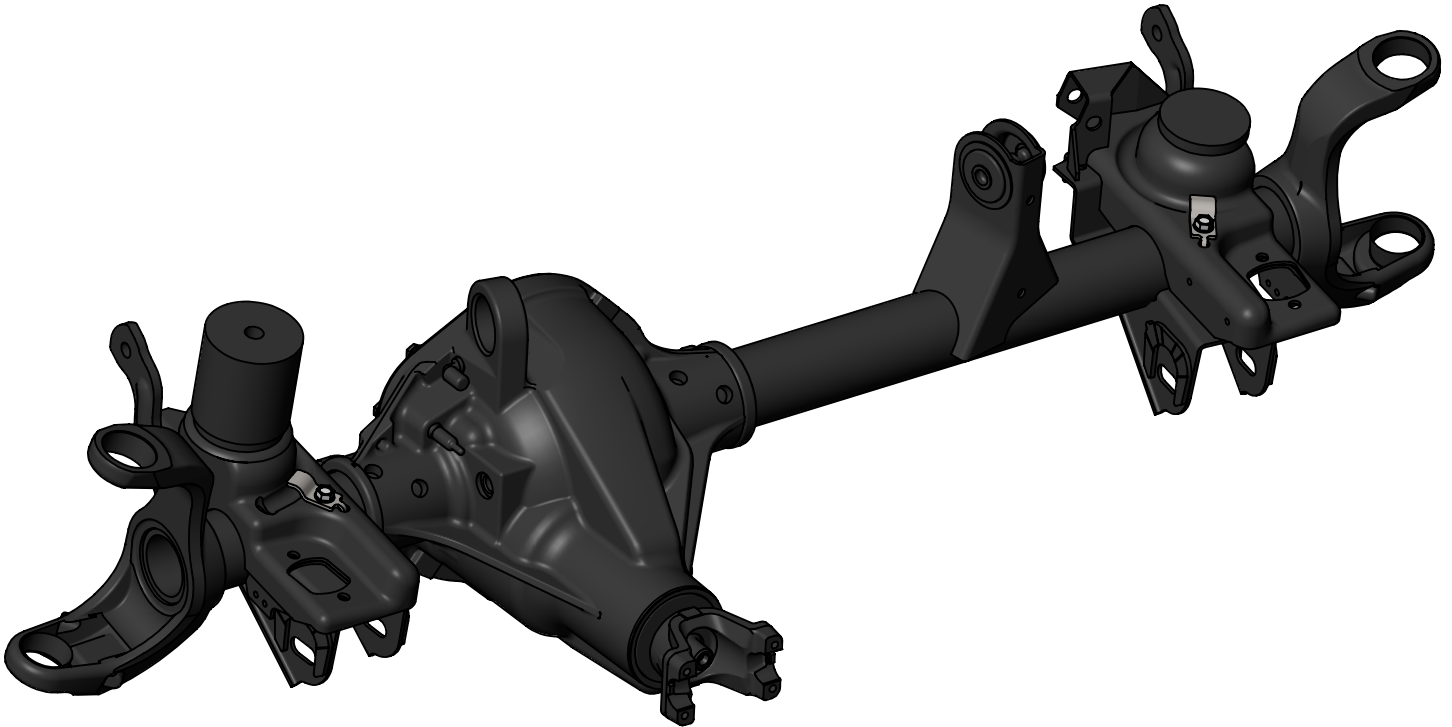

**Clayton Off Road
COR-1200508
Jeep Wrangler Rear Coil Spring Retainer Kit (1997-2006, TJ/LJ)**

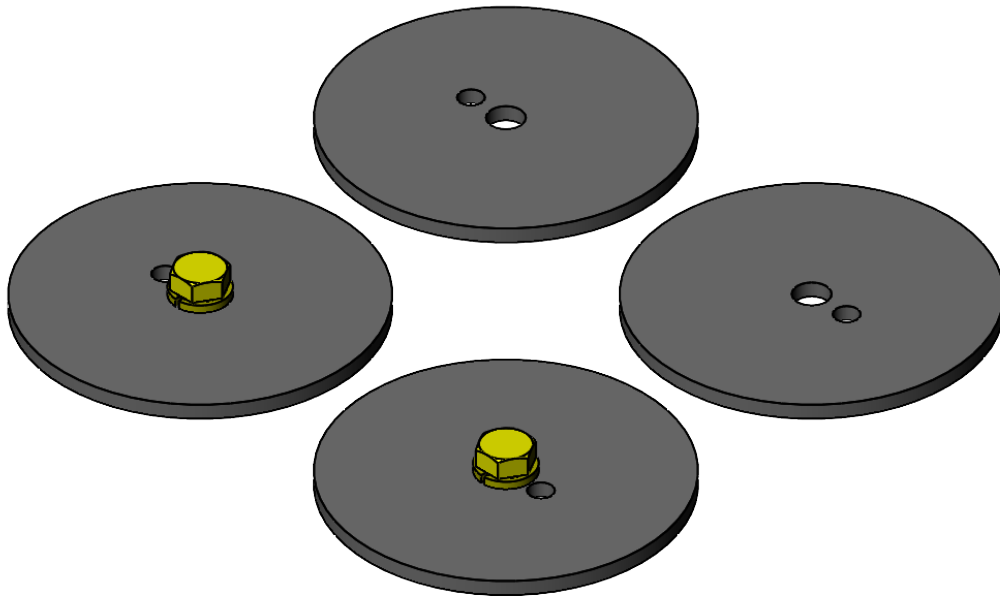

NOTES: This product may require general welding, fabrication and automotive mechanic skills. Welding should only be done by a competent welder. Clayton Off Road implies no guarantees or warranties and is not liable for improper installation. Some grinding and fitment may be required when installing this product. Every vehicle varies slightly and some fabrication may be required. For more information please visit our website.

Refer to picture below.

Step 1: Remove spring.

Step 2: Remove upper rubber bump stop and cup.

Step 3: Center spring retainer on lower coil bucket.

Step 4: Mark hole location on lower coil bucket.

Step 5: Drill 5/16" hole in lower coil bucket.

Step 6: Tap hole 3/8"-16

Step 7: Install spring and compress it slightly to hold in place.

Step 8: Install upper spring retainer and cup.

Step 9: Install lower spring retainer.

Step 10: Put rubber bump stop inside spring.

Step 11: Compress spring to ride height.

Step 12: Tighten upper and lower bolts.

Step 13: Install rubber bump stop in cup.

There is an optional rear bump stop kit available which goes on top of the lower spring retainer. It is part number 1400200.

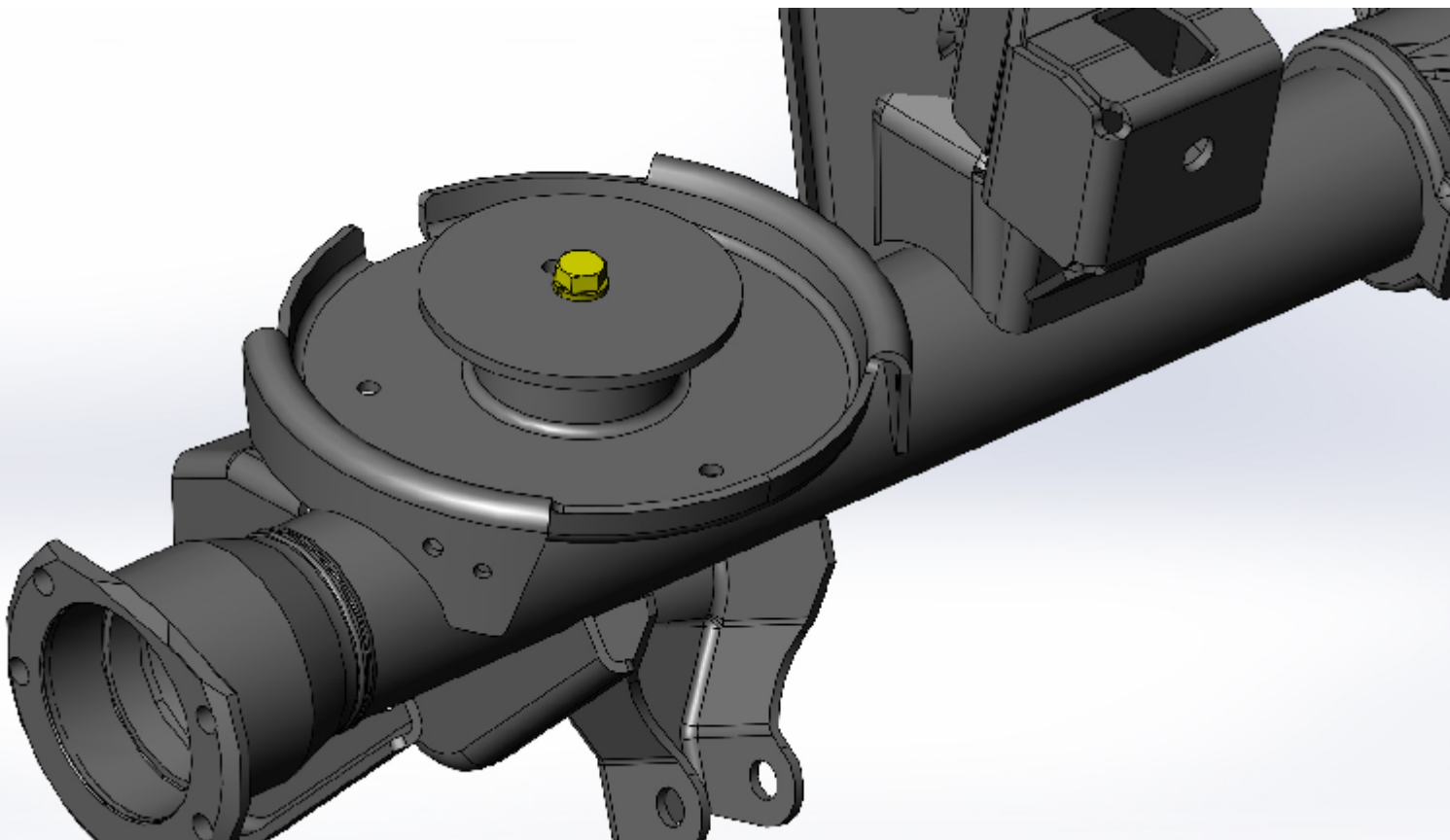

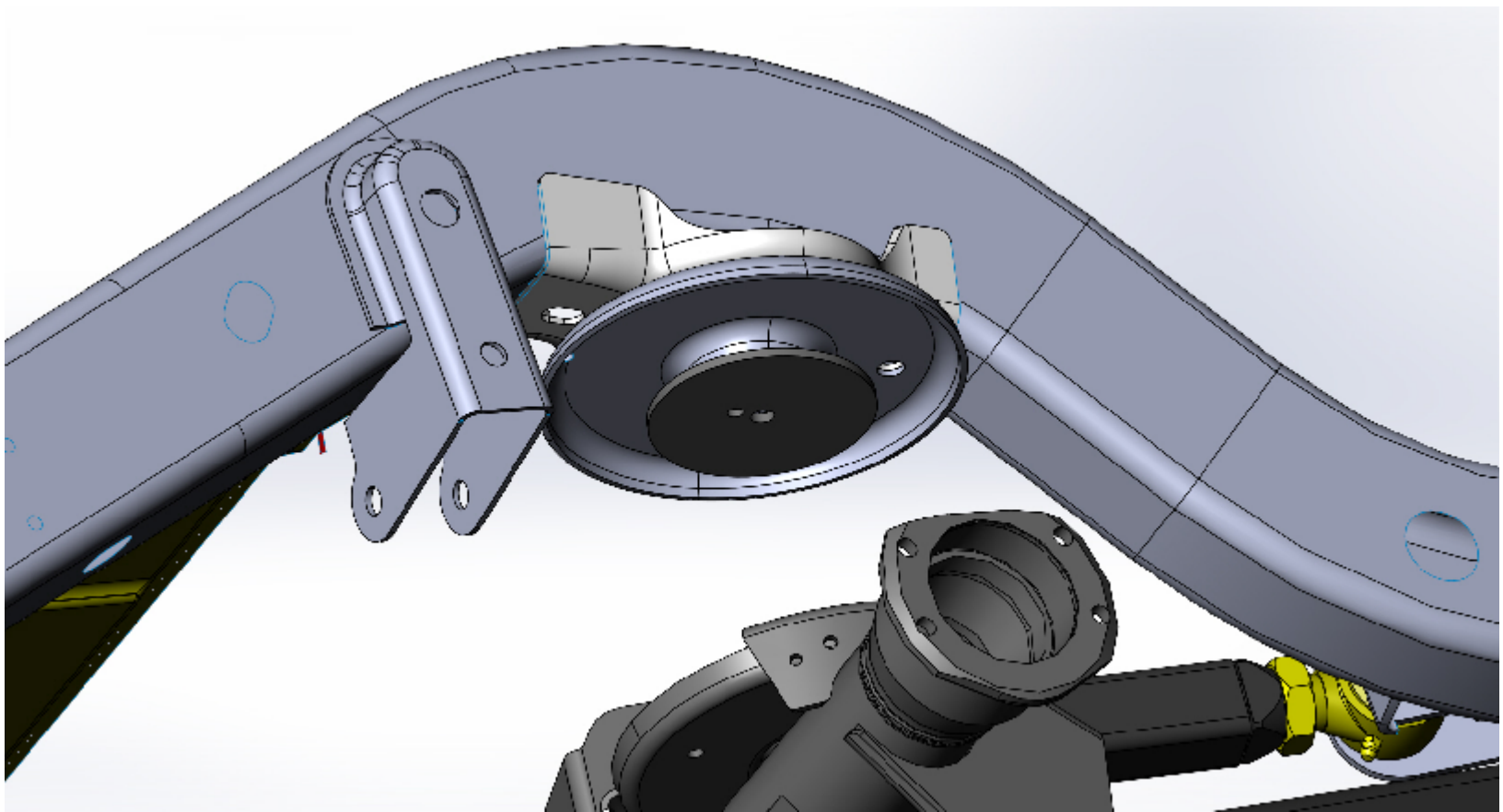

**CLAYTON OFF ROAD
COR-1200510
JEEP WRANGLER REAR SHOCK EXTENSIONS (1997-2006, TJ/LJ)**

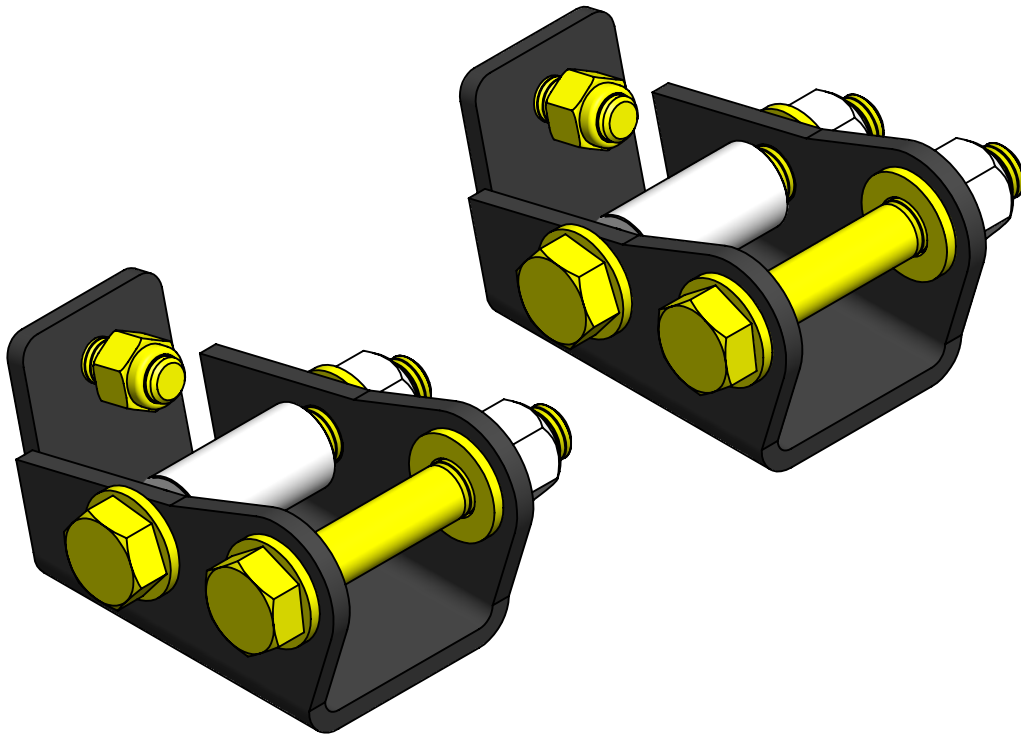

NOTES: This product may require general welding, fabrication and automotive mechanic skills. Welding should only be done by a competent welder. Clayton Off Road implies no guarantees or warranties and is not liable for improper installation. Some grinding and fitment may be required when installing this product. Every vehicle varies slightly and some fabrication may be required. For more information please visit our website.

- Step 1: Remove lower shock bolt.
- Step 2: Slide shock extension over shock mount.
- Step 3: Install 3/8"-16 x 1" bolt from front.
- Step 4: Install 3/8"-16 lock nut.
- Step 5: Hold aluminum spacer in shock mount.
- Step 6: Install M12 x 1.75 x 80mm bolt with M12 washers.
- Step 7: Install M12 x 1.75 lock nut.
- Step 8: Tighten 3/8" bolt to 30 ft-lbs.
- Step 9: Tighten M12 bolt to 70 ft-lbs.
- Step 10: Use two M12 washers as spacers on the either of the shock eye.
- Step 11: Install M12 x 1.75 x 80mm bolt with washers.
- Step 12: Install M12 x 1.75 lock nut.
- Step 13: Tighten M12 bolt to 70 ft-lbs.

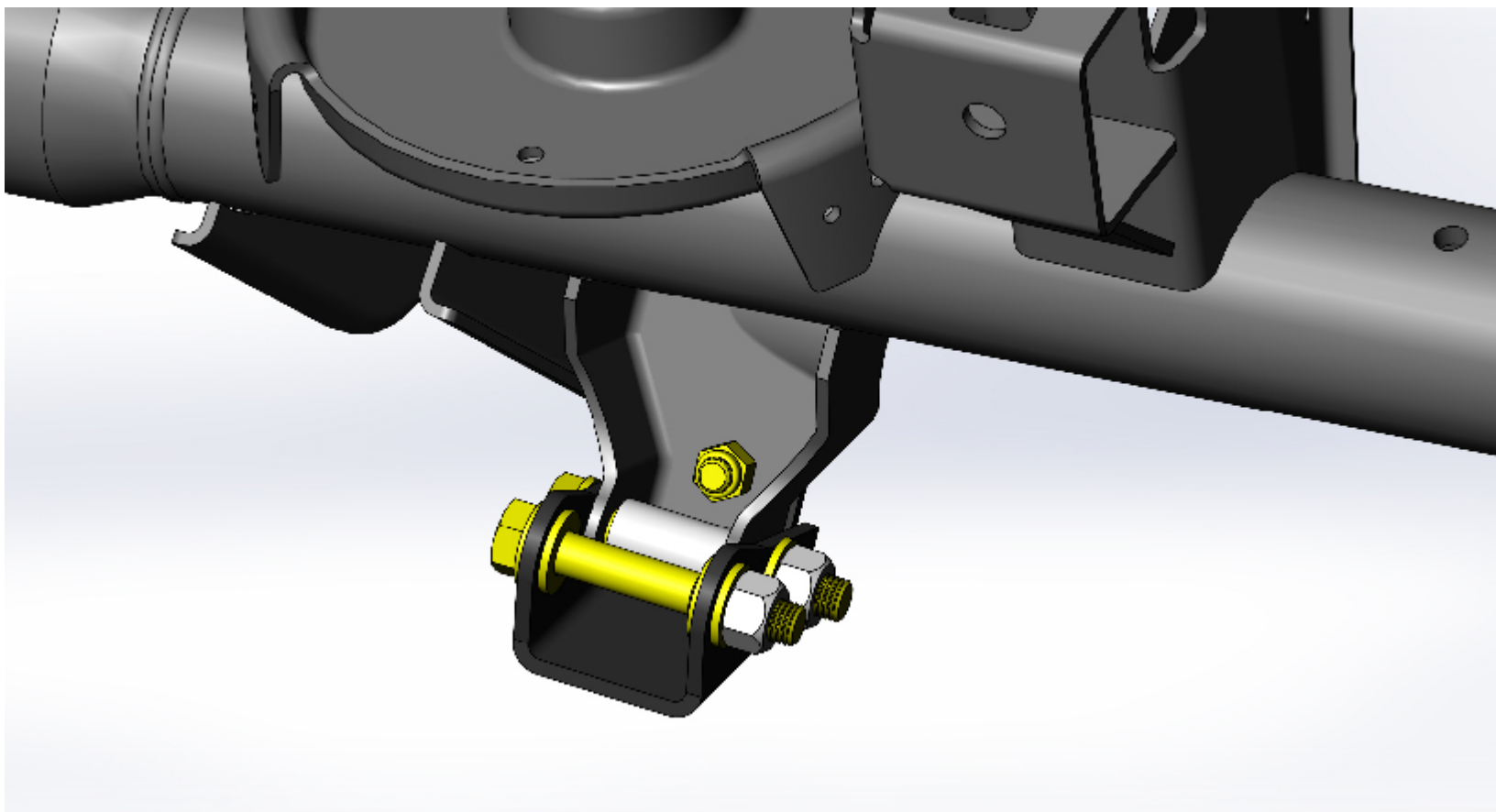

**CLAYTON OFF ROAD
COR-1300101
JEEP REAR BRAKE LINE (1984-2006, TJ/LJ/XJ/ZJ/WJ)**

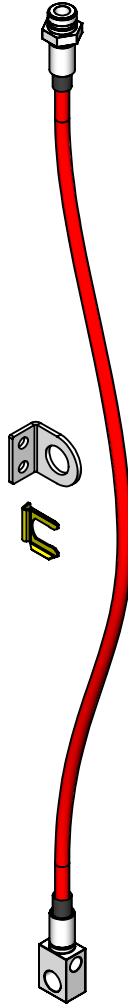

NOTES: This product may require general welding, fabrication and automotive mechanic skills. Welding should only be done by a competent welder. Clayton Off Road implies no guarantees or warranties and is not liable for improper installation. Some grinding and fitment may be required when installing this product. Every vehicle varies slightly and some fabrication may be required.

For more information please visit our website.

- Step 1: Remove vent tube on axle.
- Step 2: Loosen vent tube bolt about 4 turns.
- Step 3: Use a tubing wrench to brake the two hard line nuts loose at the axle.
- Step 4: Use a tubing wrench to brake the hard line nuts loose at the frame.
- Step 5: Remove hard line from brake line at frame.
- Step 6: Remove the bolt holding the brake line to the frame.
- Step 7: Remove the two hard lines and vent tube bolt at the axle.
- Step 8: Remove old brake line.
- Step 9: Install new extended brake line at frame with new bracket and retaining clip.
- Step 10: Connect hard line to new extended brake line and tighten nut.
- Step 11: Start the bolt into the extended brake line to the axle using the vent tube bolt.
- Step 12: Connect the two hard lines to the distribution block.
- Step 13: Tighten the brake line nuts.
- Step 14: Tighten the vent tube bolt.
- Step 15: Attach vent tube.
- Step 14: Bleed brake lines using bleeder valve on the calipers.
- Step 15: Top off brake fluid.
- Step 16: Start vehicle and apply brakes.
- Step 17: Check for leaks.

**CLAYTON OFF ROAD
COR-1300102
JEEP FRONT BRAKE LINES (1984-2006, TJ/LJ/XJ/ZJ/WJ)**

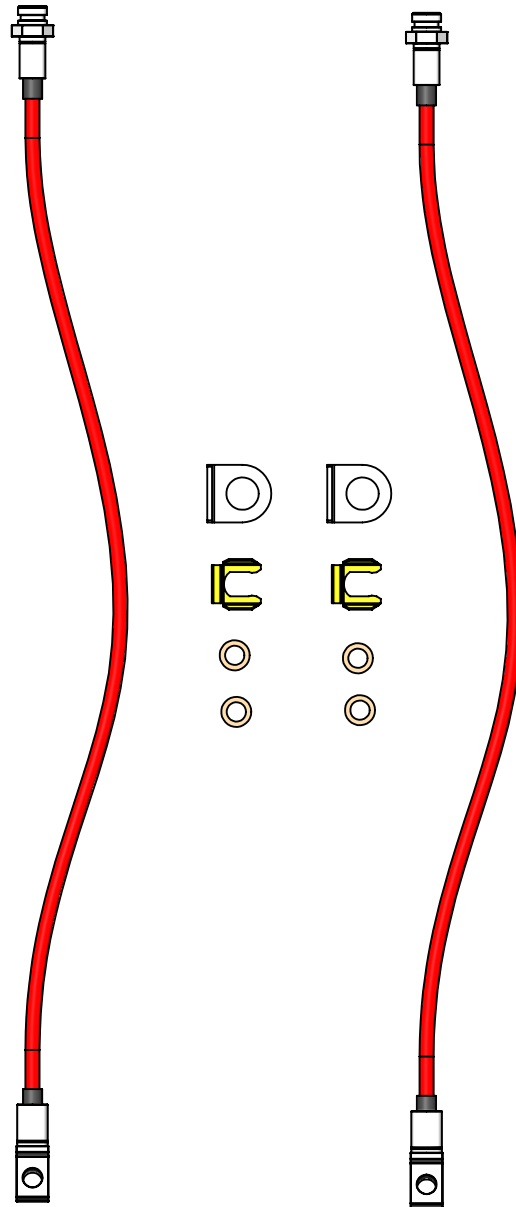

NOTES: This product may require general welding, fabrication and automotive mechanic skills. Welding should only be done by a competent welder. Clayton Off Road implies no guarantees or warranties and is not liable for improper installation. Some grinding and fitment may be required when installing this product. Every vehicle varies slightly and some fabrication may be required.

For more information please visit our website.

Step 1: Remove banjo bolt on caliper.

Step 2: Remove hard line from brake line at frame.

Step 3: Remove brake line retaining clip.

Step 4: Remove old brake line.

Step 5: Install new bracket.

Step 6: Install new extended brake line at frame with new retaining clip.

Step 7: Connect hard line to new extended brake line and tighten nut.

Step 8: Connect extended brake line at caliper using banjo bolt and new washers.

Step 9: Tighten banjo bolt.

Step 10: Repeat steps 1 through 8 on other side.

Step 11: Bleed brake lines using bleeder valve on the calipers.

Step 12: Top off brake fluid.

Step 13: Start vehicle and apply brakes.

Step 14: Check for leaks.

**Clayton Off Road
COR-1400200
Jeep Wrangler Rear Bump Stops (1997-2006, TJ/LJ)**

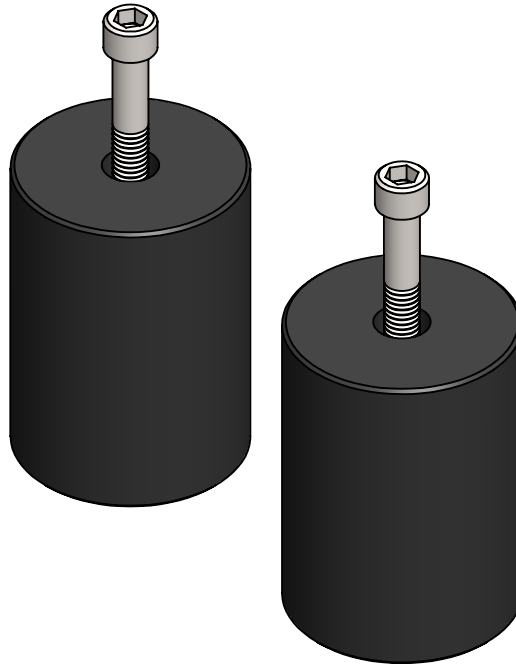

NOTES: This product may require general welding, fabrication and automotive mechanic skills. Welding should only be done by a competent welder. Clayton Off Road implies no guarantees or warranties and is not liable for improper installation. Some grinding and fitment may be required when installing this product. Every vehicle varies slightly and some fabrication may be required. For more information please visit our website.

Refer to picture below.

Step 1: Remove spring.

Step 2: Center bump stop on lower coil bucket.

Step 3: Mark hole location on lower coil bucket.

Step 4: Drill 5/16" hole in lower coil bucket.

Step 5: Tap hole 3/8"-16

Step 5: Insert bump stop with bolt into spring and install spring.

Step 6: Tighten bolt.

There is an optional rear coil spring retainer kit available which goes under the bump stop to hold the spring in place on the upper and lower coil buckets. It is part number 1200508.

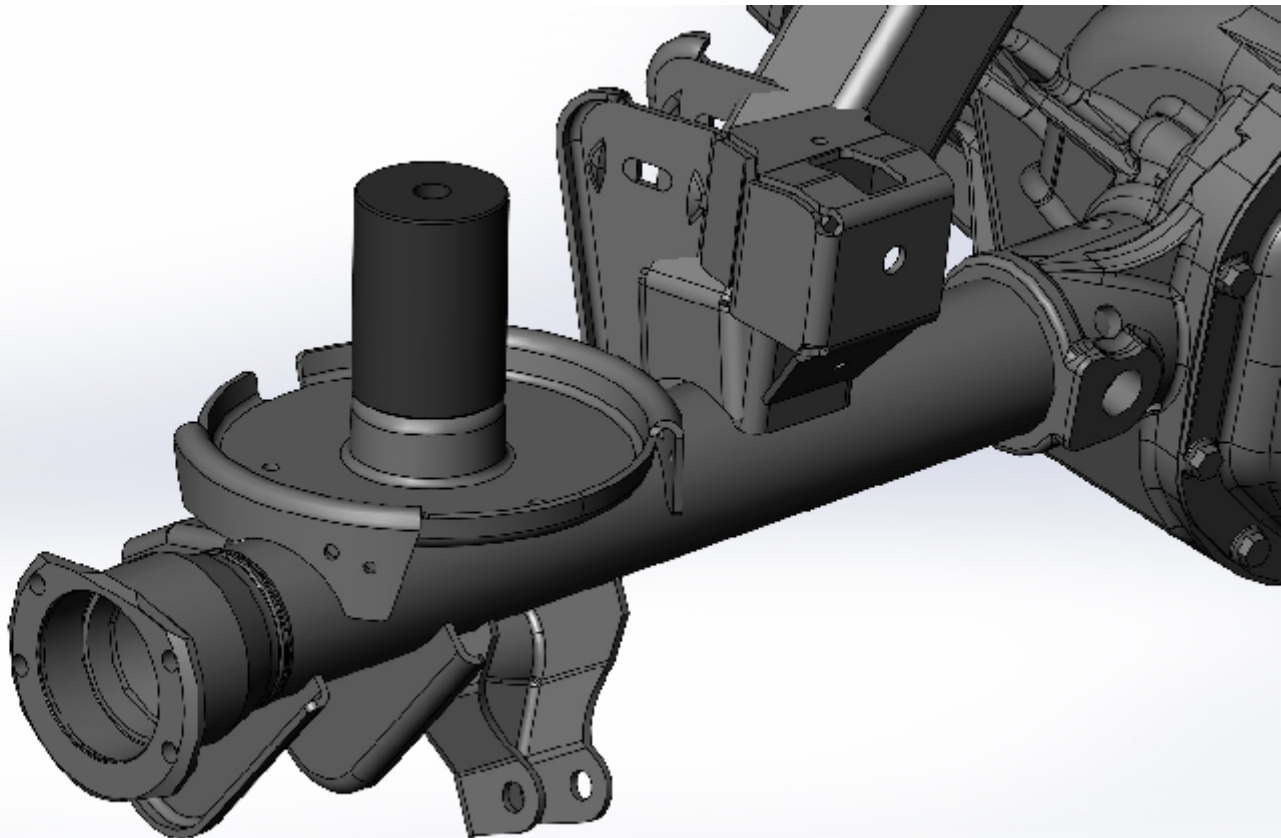

**CLAYTON OFF ROAD
COR-1408100
JEEP FRONT BUMP STOPS (1984 & UP, TJ/LJ/XJ/ZJ/JK/JL/JT)**

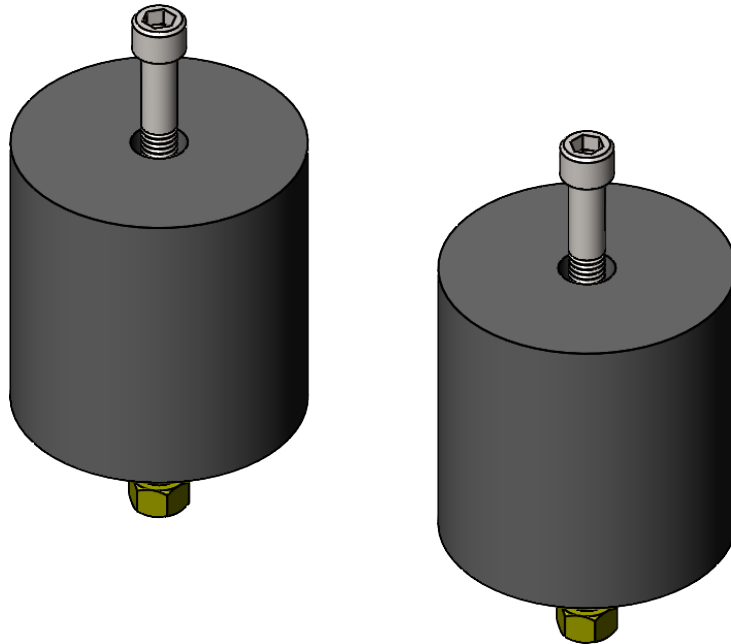

NOTES: This product may require general welding, fabrication and automotive mechanic skills. Welding should only be done by a competent welder. Clayton Off Road implies no guarantees or warranties and is not liable for improper installation. Some grinding and fitment may be required when installing this product. Every vehicle varies slightly and some fabrication may be required. For more information please visit our website.

Refer to picture below.

Instructions for Wrangler models JK/JL and Gladiator.

Step 1: Remove spring.

Step 2: Center bump stop on lower coil bucket.

Step 3: Mark hole location on lower coil bucket.

Step 4: Drill 13/32" hole in lower coil bucket.

Step 5: Insert bump stop into spring and install spring.

Step 6: Install nut and tighten bolt.



Refer to picture below.

Instructions for Wrangler models TJ/LJ, Cherokee XJ and Grand Cherokee ZJ

Step 1: Remove spring.

Step 2: Center bump stop on lower coil bucket.

Step 3: Mark hole location on lower coil bucket.

Step 4: Drill 5/16" hole in lower coil bucket.

Step 5: Tap hole 3/8"-16.

Step 5: Insert bump stop with bolt into spring and install spring.

Step 6: Tighten bolt.



**Clayton Off Road
COR-1700100**

Jeep OverLand Plus Short Lower Control Arms (1984-2006, TJ/LJ/XJ/ZJ)



NOTES: This product may require general welding, fabrication and automotive mechanic skills. Welding should only be done by a competent welder. Clayton Off Road implies no guarantees or warranties and is not liable for improper installation. Some grinding and fitment may be required when installing this product. Every vehicle varies slightly and some fabrication may be required. For more information please visit our website.

Refer to pictures below.

Step 1: Remove old control arm on one side.

Step 2: Position axle.

Step 3: Measure length from axle side mount to frame side mount.

Step 4: Adjust control arm to length and run jam nut up to control arm tube insert.

Step 5: Install new control arm with adjustment end on frame.

Step 6: Install control arm bolts and nuts.

Step 7: Torques both bolts to 90 ft-lb.

Step 8: Tighten jam nut using a 46mm or 1-13/16" wrench.

Step 9: Repeat steps 1 to 9 on other side.

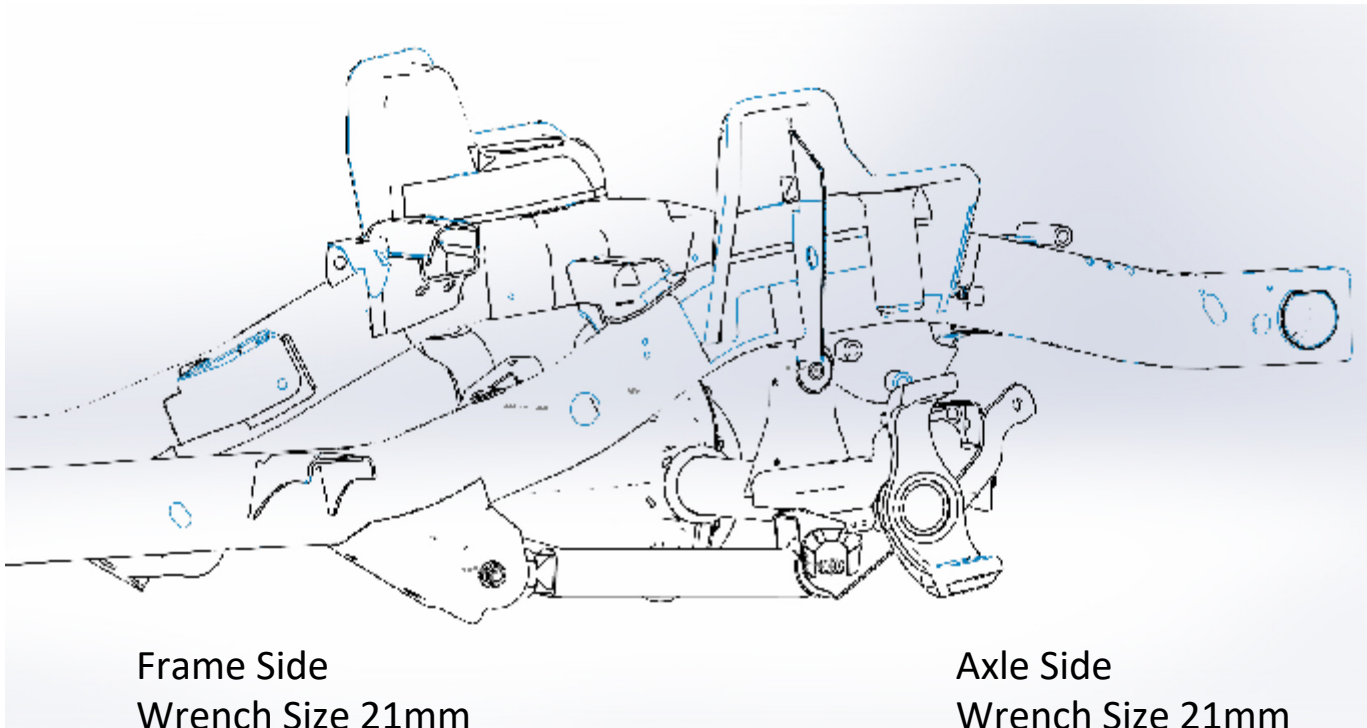

Axle Side
Wrench Size 21mm
Torque 90 ft-lb

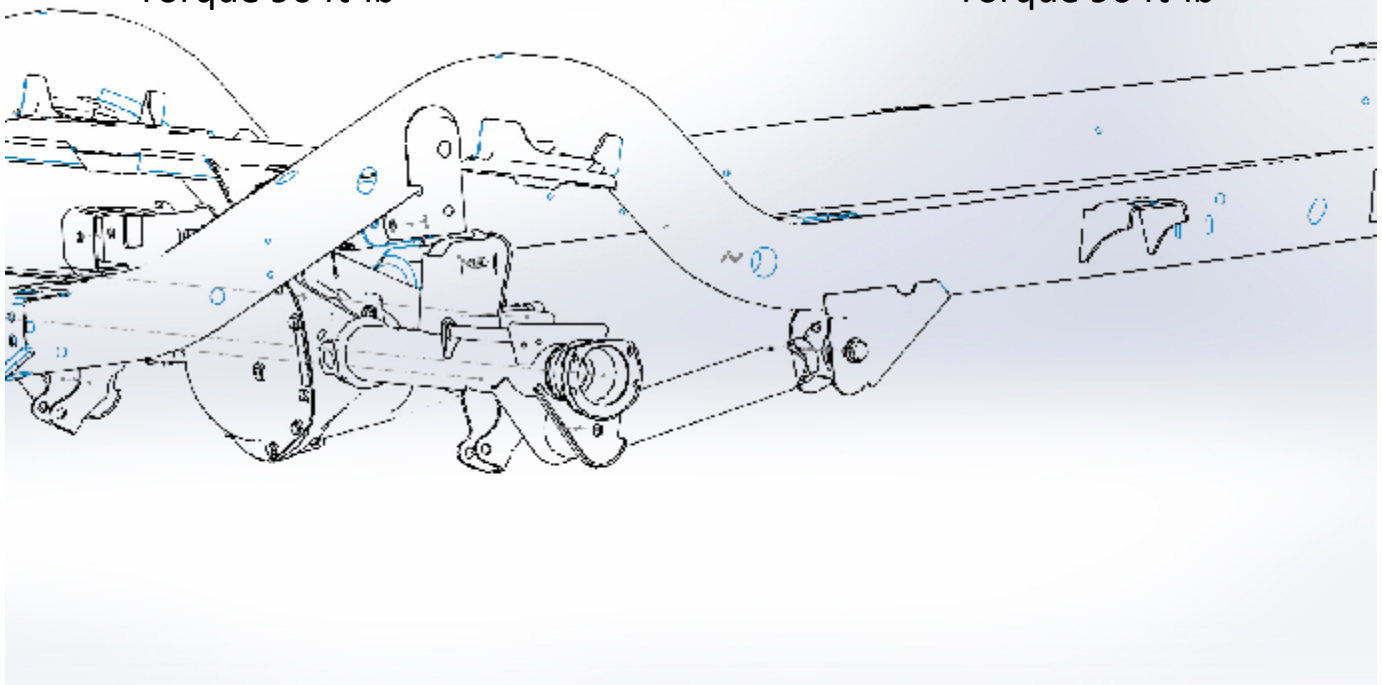

Refer to drawing below for minimum and maximum lengths.

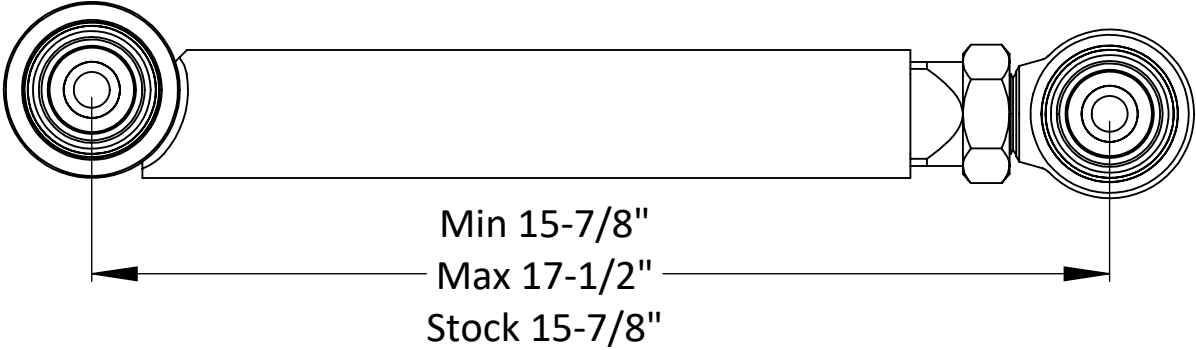

**Clayton Off Road
COR-1700101**

Jeep OverLand Plus Short Upper Control Arms (1984-2006, TJ/LJ/XJ/ZJ)



NOTES: This product may require general welding, fabrication and automotive mechanic skills. Welding should only be done by a competent welder. Clayton Off Road implies no guarantees or warranties and is not liable for improper installation. Some grinding and fitment may be required when installing this product. Every vehicle varies slightly and some fabrication may be required. For more information please visit our website.

Refer to pictures below.

Step 1: Support axle from rotating, a floor or bottle jack works well.

Step 2: Remove old control arms.

Step 3: Drill upper control mounts at the frame to 1/2"

Step 4: Set caster to 4.0 to 5.0 degrees by adjusting the height of the jack.

Step 5: Install arms at frame side.

Step 6: Adjust control arm to length so that bolts can easily be installed at axle end.

Step 7: Remove jack, and check caster.

Step 8: Torque M10 bolts at axle to 50 ft-lb and M12 bolts at frame to 90 ft-lb.

Step 9: Tighten jam nut using a 1-7/16" wrench.

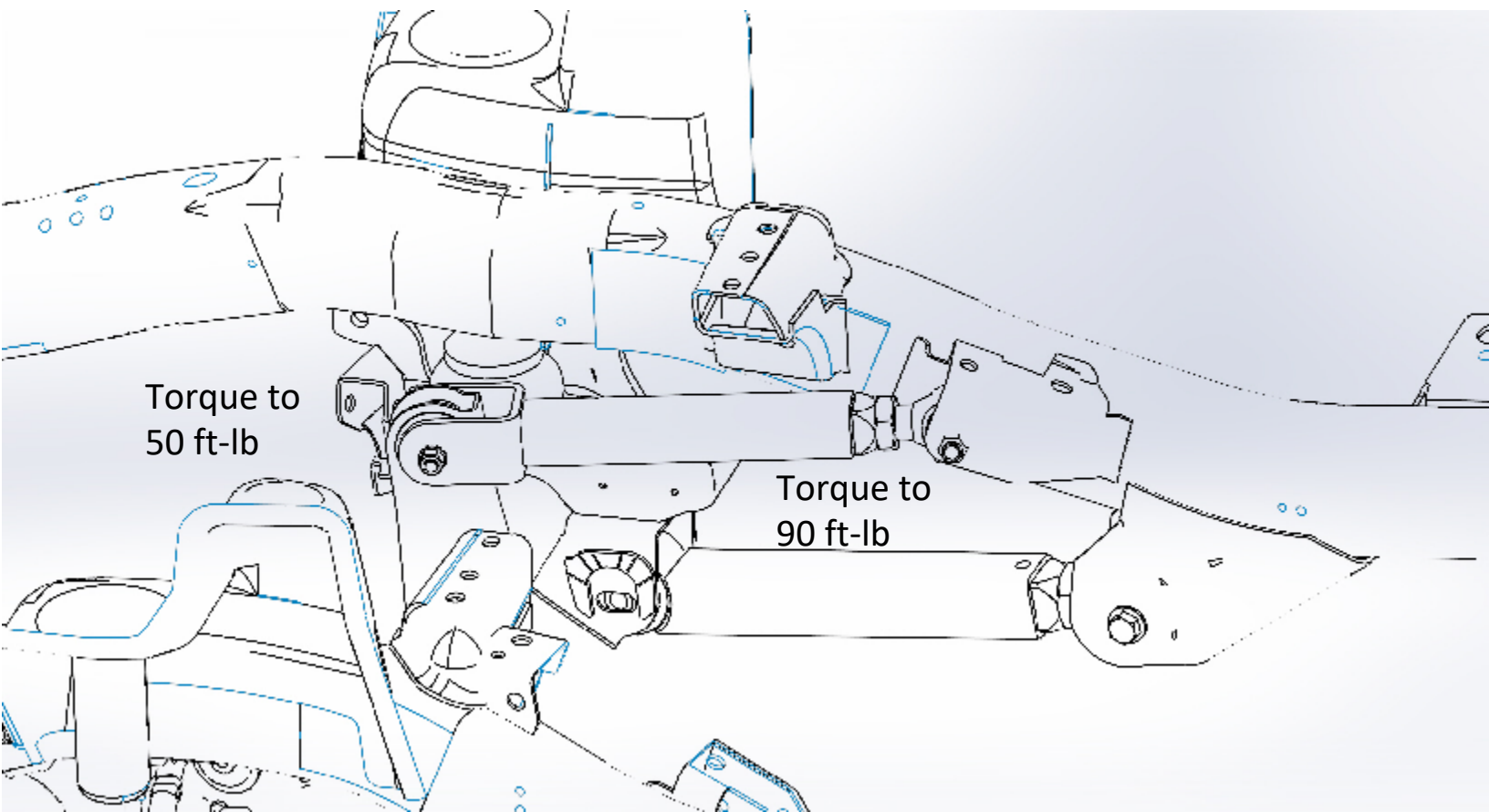

Refer to drawing below for minimum and maximum lengths.

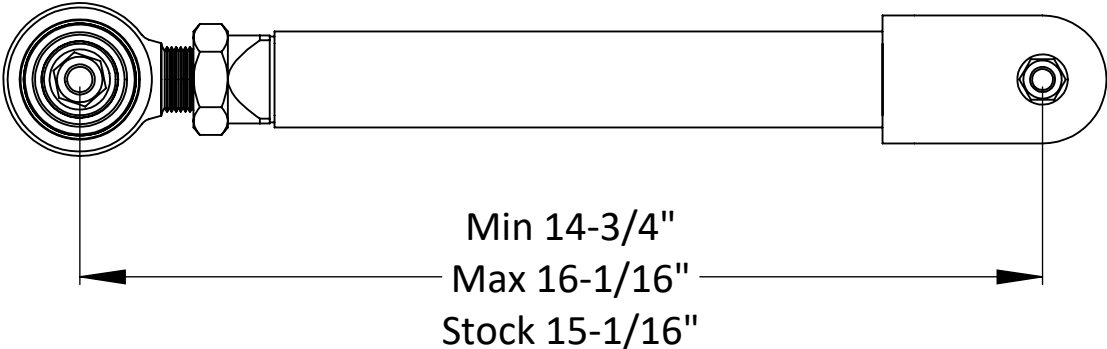

**Clayton Off Road
COR-1700102
Jeep Overland Plus Rear Upper Control Arms (1993-2006, TJ/LJ/ZJ)**

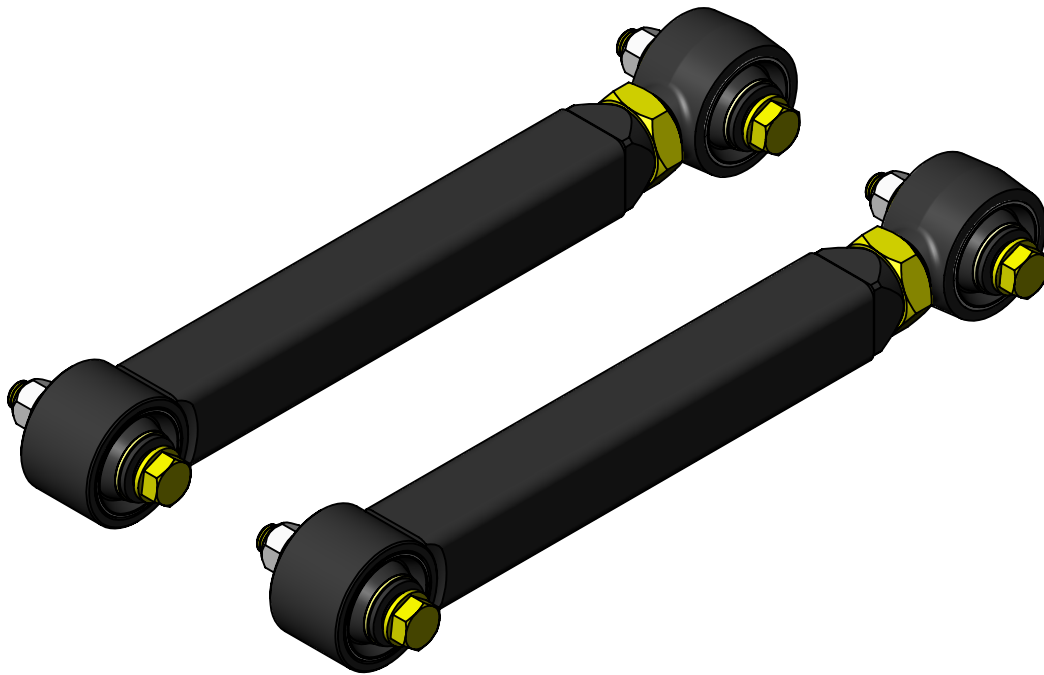

NOTES: This product may require general welding, fabrication and automotive mechanic skills. Welding should only be done by a competent welder. Clayton Off Road implies no guarantees or warranties and is not liable for improper installation. Some grinding and fitment may be required when installing this product. Every vehicle varies slightly and some fabrication may be required. For more information please visit our website.

Refer to pictures below.

Step 1: Support axle from rotating, a floor or bottle jack works well.

Step 2: Remove old control arms.

Step 3: All 4 control arm mounting locations need to be drilled out to 1/2" diameter.

Step 4: Set pinion angle desired pinion angle by adjusting the height of the jack.

Step 5: Install arms with adjuster at frame side.

Step 6: Adjust control arm to length so that bolts can easily be installed at axle end.

Step 7: Remove jack, and pinion angle.

Step 8: Torque all bolts to 90 ft-lb.

Step 9: Tighten jam nut using a 1-7/16" wrench.

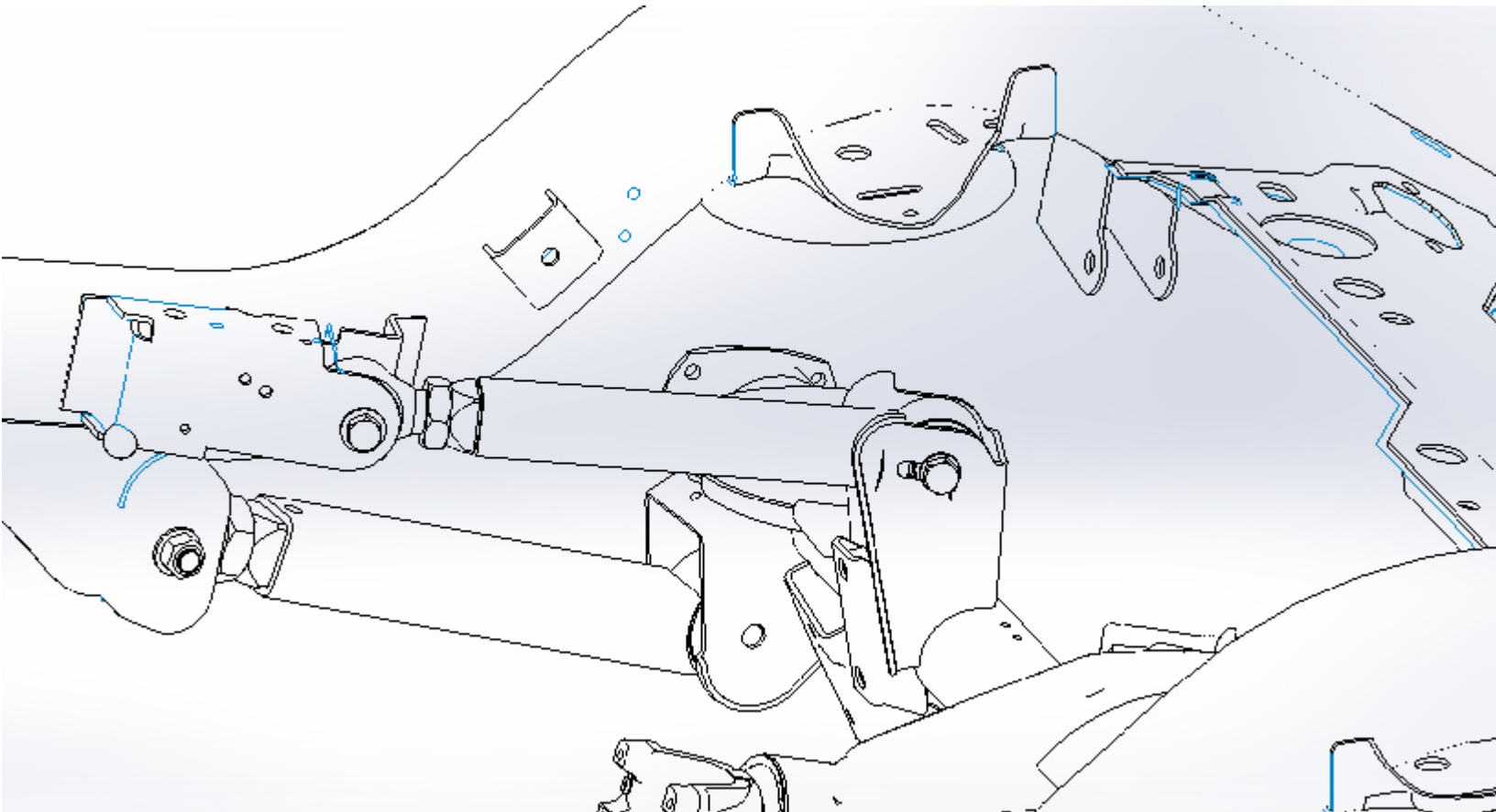

Refer to drawing below for minimum and maximum lengths.

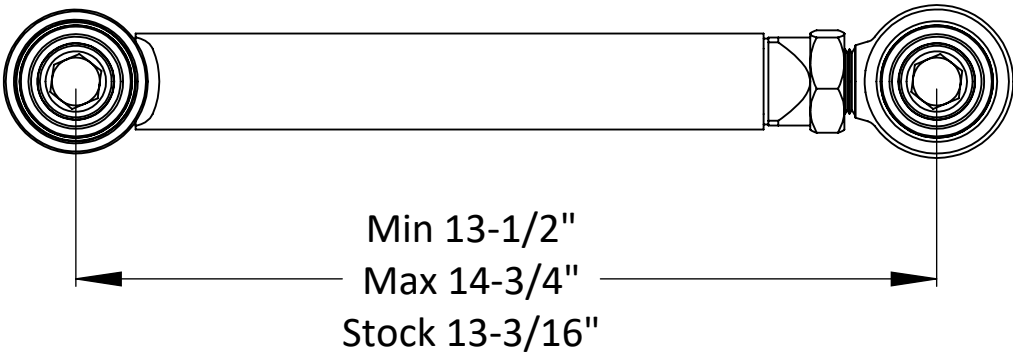

**Clayton Off Road
COR-4500205
Jeep Adjustable Front Track Bar (1984-2006, TJ/LJ/XJ/ZJ)**



NOTES: This product may require general welding, fabrication and automotive mechanic skills. Welding should only be done by a competent welder. Clayton Off Road implies no guarantees or warranties and is not liable for improper installation. Some grinding and fitment may be required when installing this product. Every vehicle varies slightly and some fabrication may be required. For more information please visit our website.

Refer to pictures below.

Step 1: Remove steering components .

Step 2: Remove old track bar.

Step 3: Drill frame side track bar mount with 5/8" drill bit.

Step 4: Drill axle side track bar mount with 9/16" drill bit

Step 5: With vehicle at ride height center frame on axle.

Step 6: Measure length from axle side mount to frame side mount.

Step 7: Adjust track bar to length and run jam nut up to track bar tube.

Step 8: Install new track bar with adjustment end on frame.

Step 9: Install track bar 5/8" bolt on frame side with head down and bolt going up through the johnny joint and bracket.

Step 10: Put stainless steel spacer was on bolt, install lock nut.

Step 11: Torques 9/16" bolt to 110 ft-lbs. and 5/8" bolt to 150 ft-lbs.

Step 12: Tighten jam nut using a 1-7/16" wrench.

Step 13: Install steering system.

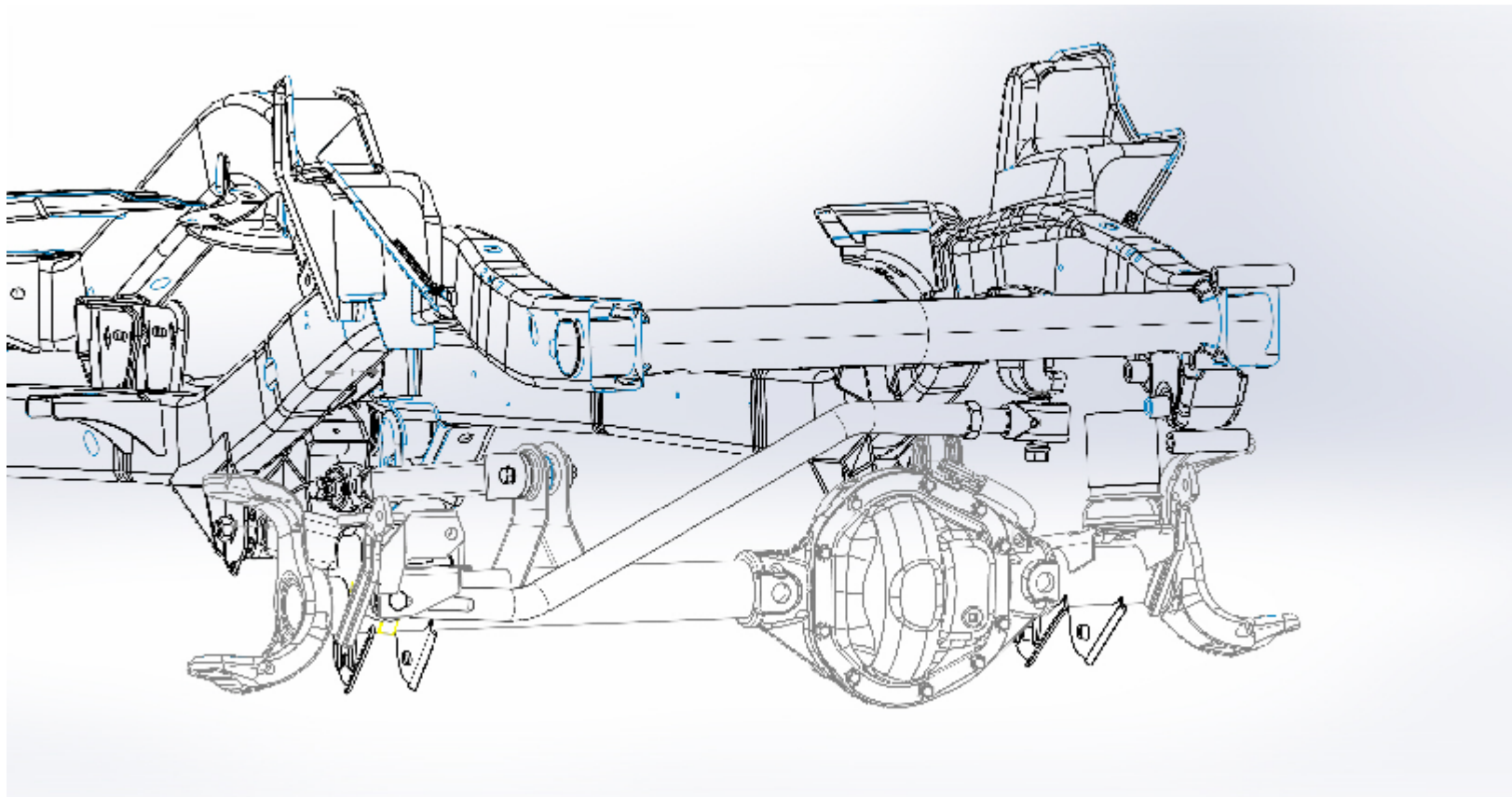

Refer to drawing below for minimum and maximum lengths.

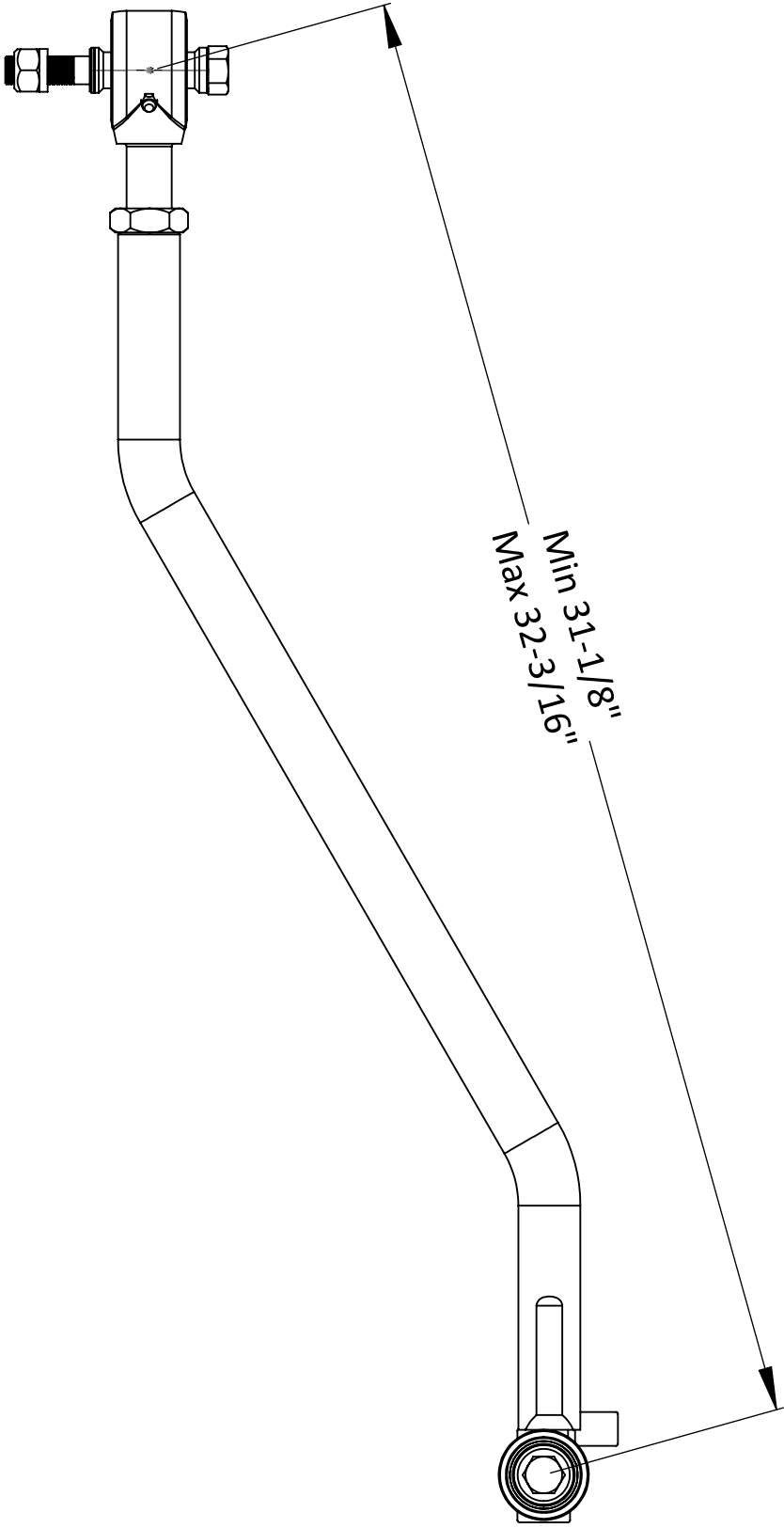

**Clayton Off Road
COR-4500210
Jeep Wrangler Adjustable Rear Track Bar (1997-2006, TJ/LJ)**



NOTES: This product may require general welding, fabrication and automotive mechanic skills. Welding should only be done by a competent welder. Clayton Off Road implies no guarantees or warranties and is not liable for improper installation. Some grinding and fitment may be required when installing this product. Every vehicle varies slightly and some fabrication may be required. For more information please visit our website.

Refer to pictures below.

Step 1: Remove old track bar.

Step 2: Center frame on axle.

Step 3: Measure length from axle side mount to frame side mount.

Step 4: Adjust track bar to length and run jam nut up to track bar tube.

Step 5: Install new track bar with adjustment end on axle.

Step 6: Install track bar bolts and nuts.

Step 7: Torques both bolts to 110 ft-lb.

Step 8: Tighten jam nut using a 1-7/16" wrench.

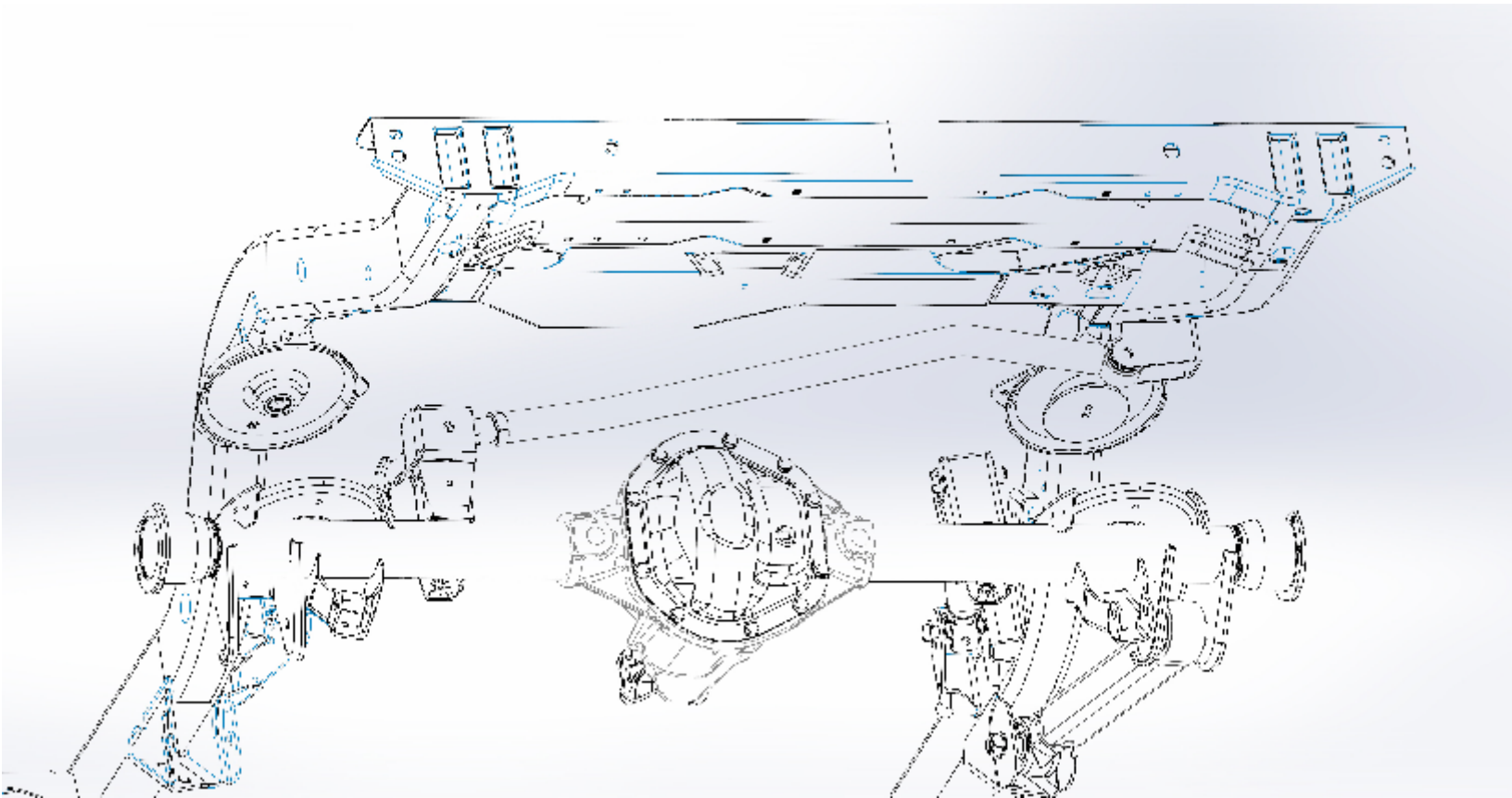

Refer to drawing below for minimum and maximum lengths.

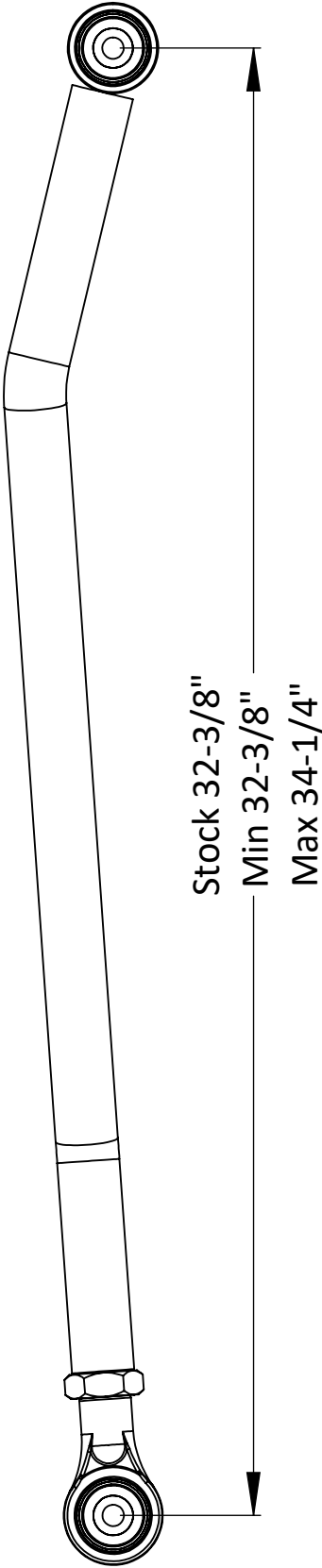

**CLAYTON OFF ROAD
COR-4500500**

JEEP WRANGLER REAR TRACK BAR RELOCATION BRACKET (1997-2006, TJ/LJ)

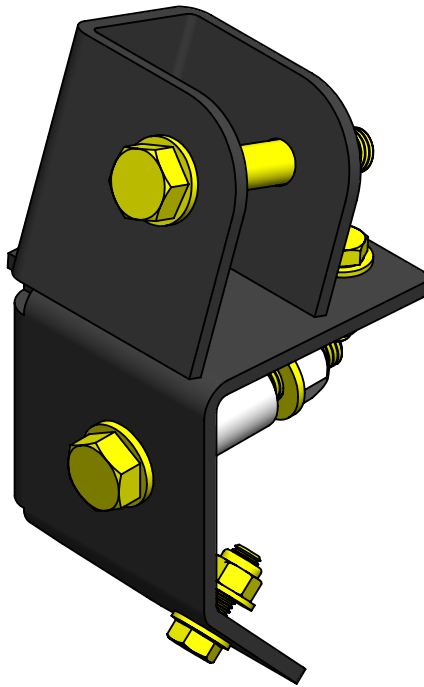

NOTES: This product may require general welding, fabrication and automotive mechanic skills. Welding should only be done by a competent welder. Clayton Off Road implies no guarantees or warranties and is not liable for improper installation. Some grinding and fitment may be required when installing this product. Every vehicle varies slightly and some fabrication may be required. For more information please visit our website.

- Step 1: Droop axle or raise body so that track bar bolt at axle is below the gas tank.
- Step 2: Removing driver side upper control arm at the axle end.
- Step 3: Remove track bar.
- Step 4: Grind off any welds on axle brackets that may interfere with relocation bracket.
- Step 5: Position relocation bracket on axle.
- Step 6: Insert spacer in old track bar mounting location.
- Step 7: Insert M12-1.75 x 80mm bolt with washers and lock nut.
- Step 8: Torque to 90 ft/lbs.
- Step 9: Drill out two bolt holes to 5/16".
- Step 10: Insert two 5/6"-18 x 1" bolts with washers and lock nuts.
- Step 11: Torque tp 40 ft/lbs.
- Step 12: Install track bar.
- Step 13: Torque bolts tp 90 ft/lbs.

Note: An adjustable track bar is recommended for centering the body over the axle and to account for any misalignment of the two track bar mounting locations. This may be caused by variations in lift heights and pinion angles.

