

**CLAYTON OFF ROAD
COR-4804351
JEEP GRAND CHEROKEE PRO SERIES REAR LONG ARM UPGRADE KIT
(1993-1998, ZJ)**

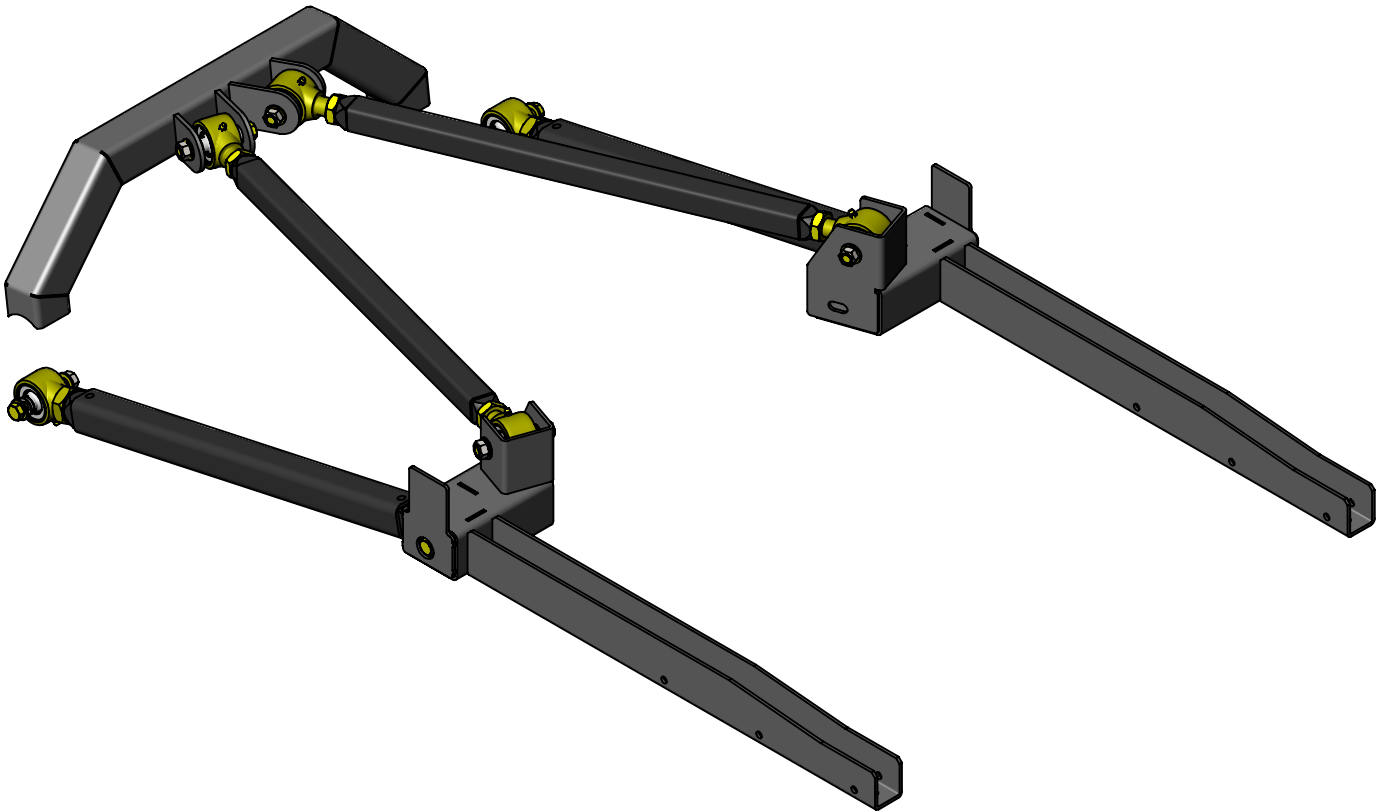

NOTES: This product requires general welding, fabrication and automotive mechanic skills. Welding should only be done by a competent welder. Clayton Off Road implies no guarantees or warranties and is not liable for improper installation. Some grinding and fitment may be required when installing this product. Every vehicle varies slightly and some fabrication may be required. For more information please visit our web site.

Refer to individual product part number instructions.

Step 2: Install part number COR-2204110 rear frame brackets.

Step 3: Install part number COR-2204210 uni-body frame rails.

Step 9: Install part number COR-1200010 4 link rear axle truss.

Step 10: Remove rear upper and lower control arms.

Step 11: Remove lower control arm brackets on frame side.

Step 12: Install part number COR-1900302 rear lower control arms.

Step 13: Install part number COR-1900102 rear upper control arms.

Notes: All final adjustments and tightening of hardware should be done with the vehicle sitting at ride height. Care should be taken to set caster and track without binding up the suspension.

There maybe some contact with the rear upper control arms and the uni-body under full compression of the suspension. The uni-body will comform to the control arm with no effect to the floor boards inside the vehicle.

**CLAYTON OFF ROAD
COR-1200010
4 LINK AXLE TRUSS (1984-2006 TJ/LJ/XJ/ZJ)**

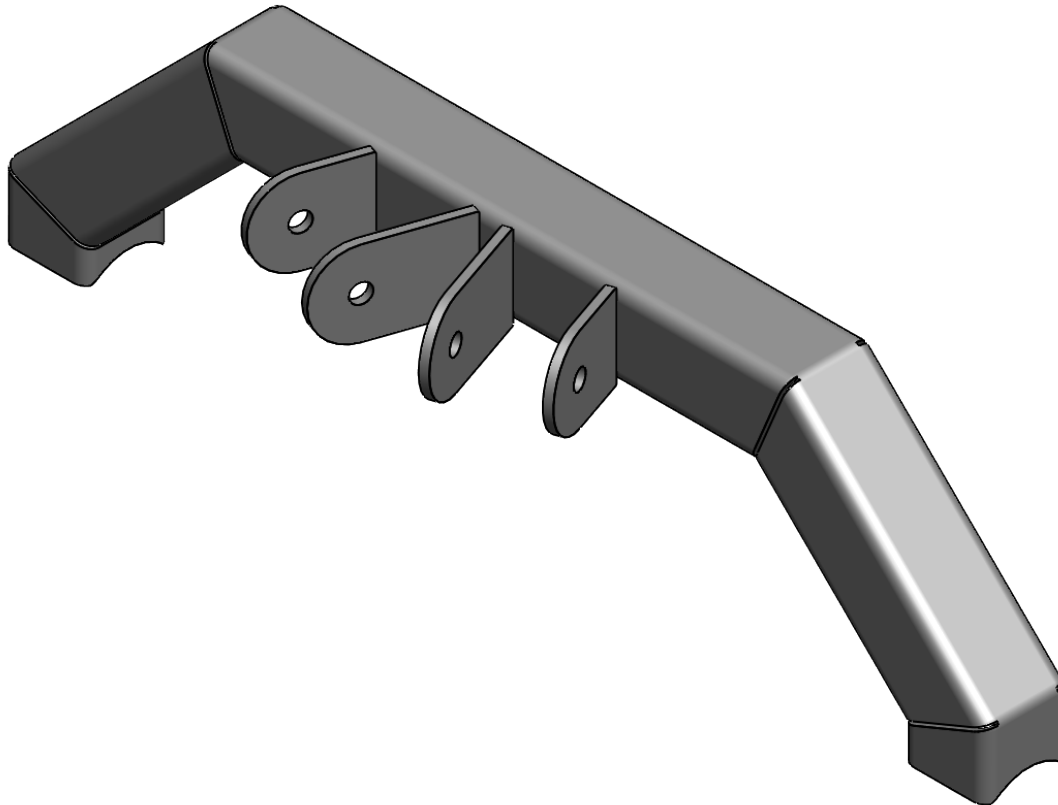

NOTES: This product may require general welding, fabrication and automotive mechanic skills. Welding should only be done by a competent welder. Clayton Off Road implies no guarantees or warranties and is not liable for improper installation. Some grinding and fitment may be required when installing this product. Every vehicle varies slightly and some fabrication may be required. For more information please visit our website.

Refer to drawing for specific vehicle for truss angle.

Step 1: Remove axle from vehicle.

Step 2: Remove old upper control arm mounts.

Step 3: Move brake lines out of the way.

Step 4: Clean axle tubes for welding.

Step 5: Center axle truss on axle at proper angle.

Step 6: Tack weld four corners of truss.

Step 7: Weld as indicated.

Step 8: Paint axle and truss.

Step 9: Install axle in vehicle.

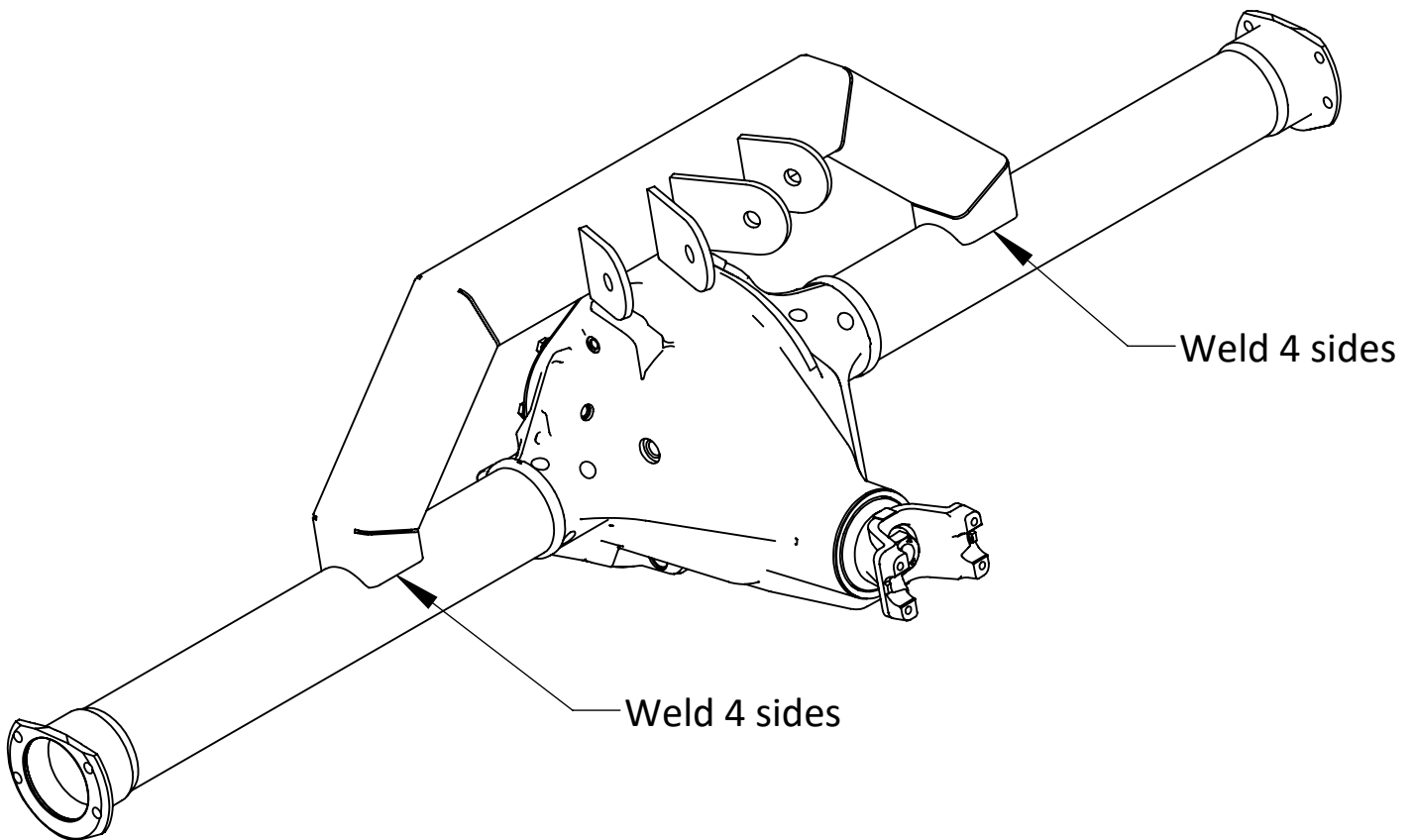

JEEP GRAND CHEROKEE 1993-1998 ZJ

Standard setup 5" - 7" of lift.

SYE kit.

Approx. 12 degree pinion angle low pinion.

Approx. 7 degrees pinion angle high pinion.

Truss angle is parallel to differential cover face or perpendicular to pinion angle.

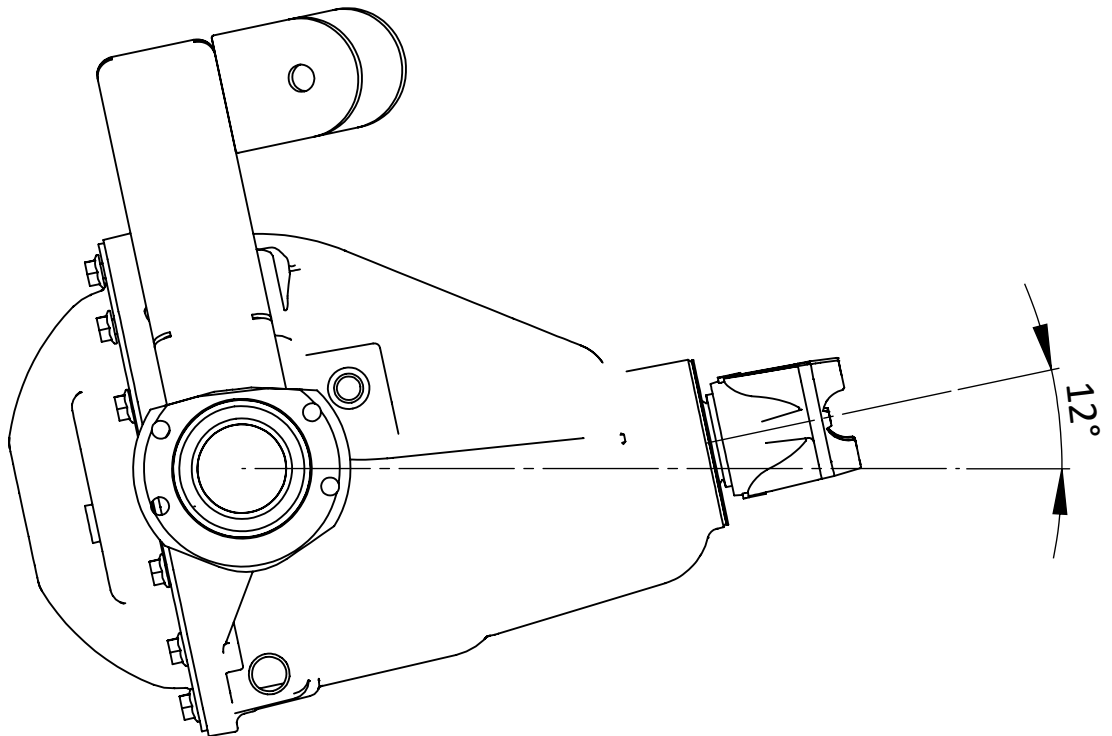

**CLAYTON OFF ROAD
COR-1900102
JEEP LONG REAR UPPER CONTROL ARMS (TJ/LJ/ZJ/WJ 1993-2006)**



NOTES: This product may require general welding, fabrication and automotive mechanic skills. Welding should only be done by a competent welder. Clayton Off Road implies no guarantees or warranties and is not liable for improper installation. Some grinding and fitment may be required when installing this product. Every vehicle varies slightly and some fabrication may be required. For more information please visit our website.

Refer to drawing view below.

Step 1: Set both arms as close to recommended length as possible with grease fittings lined up.

Step 2: Set desired pinion angle. (1 to 2 degrees down is recommended for CV style drive shafts, a bottle jack works well for this.)

Step 3: Center chassis over axle. (Ratchet straps work well for this.)

Step 4: Install one arm at frame end with grease fittings up.

Step 5: Adjust the length of the arms so that you can easily get the bolt in at the axle end with the grease fitting up.

Step 6: The center ball of the Johnny Joint may need to be aligned for the bolt to get the bolt to go in easily.

Step 7: Repeat steps 4 and 6 on other side.

Step 8: Tighten bolts after vehicle is sitting at ride height.

Step 9: Tighten jam nuts. (We recommend a 1 7/16" combination wrench for this. We also recommend cutting the box end off the wrench and getting a three foot piece pipe to put over the end of the wrench for leverage. Inserting a large screw driver between the joint body and the mount will hold the housing joint straight.)

Step 10: The joints are pre greased so initial greasing is not required. (We do recommend greasing the joints every time you change your oils or grease other components on your vehicle. Use a hand grease gun not a pneumatic grease gun.)

Recommended control arm length for 4.0" to 7.0" of lift is 34".

Some adjustment of this measurement maybe performed for special applications as long as the length stays within the minimum and maximum lengths shown below.

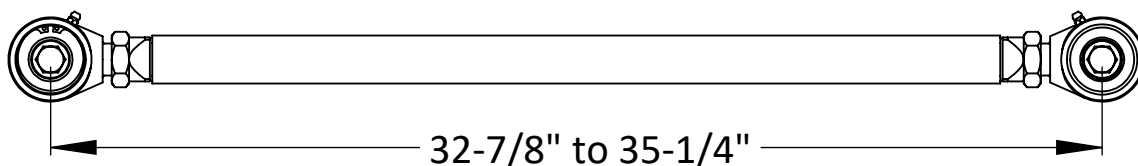

CLAYTON OFF ROAD

COR-1900302

JEEP PRO SERIES LONG REAR LOWER CONTROL ARMS (1984-2006 TJ/LJ/ZJ)



NOTES: This product may require general welding, fabrication and automotive mechanic skills. Welding should only be done by a competent welder. Clayton Off Road implies no guarantees or warranties and is not liable for improper installation. Some grinding and fitment may be required when installing this product. Every vehicle varies slightly and some fabrication may be required. For more information please visit our website.

Refer to drawing view below and individual product part number instructions.

Step 1: Set one arm as close to recommended length as possible with grease fitting down.

Step 2: Set second arm to same length with grease fitting down. (Use two 9/16" bolts in each end of both arms.)

Step 3: Bolt control arm into rear bracket.

Step 4: Bolt control arm into axle.

Step 5: Repeat steps 3 and 4 on other side.

Step 6: Tighten bolts after vehicle is sitting at ride height.

Step 7: Tighten jam nuts. (We recommend a 46 mm or 1 13/16" combination wrench for this. We also recommend cutting the box end off the wrench and getting a three foot piece pipe to put over the end of the wrench for leverage. Inserting a large screw driver between the joint body and the mount will hold the housing joint straight.)

Step 8: The joints are pre greased so initial greasing is not required. (We do recommend greasing the joints every time you change your oils or grease other components on your vehicle. Use a hand grease gun not a pneumatic grease gun.)

Step 9: Remove grease fittings and install set screws.

Recommended control arm length for 4.0" to 7.0" of lift is 31.5".

Some adjustment of this measurement maybe performed for special applications as long as the length stays within the minimum and maximum lengths shown below.

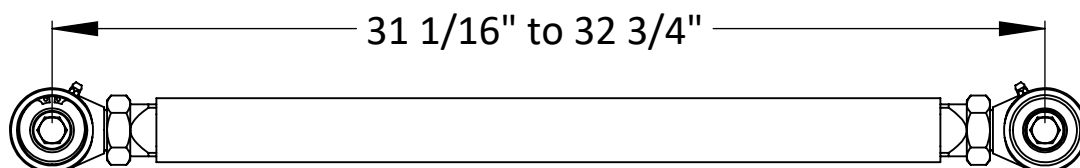

**CLAYTON OFF ROAD
COR-2204110
JEEP GRAND CHEROKEE REAR FRAME BRACKETS (1993-1998, ZJ)**

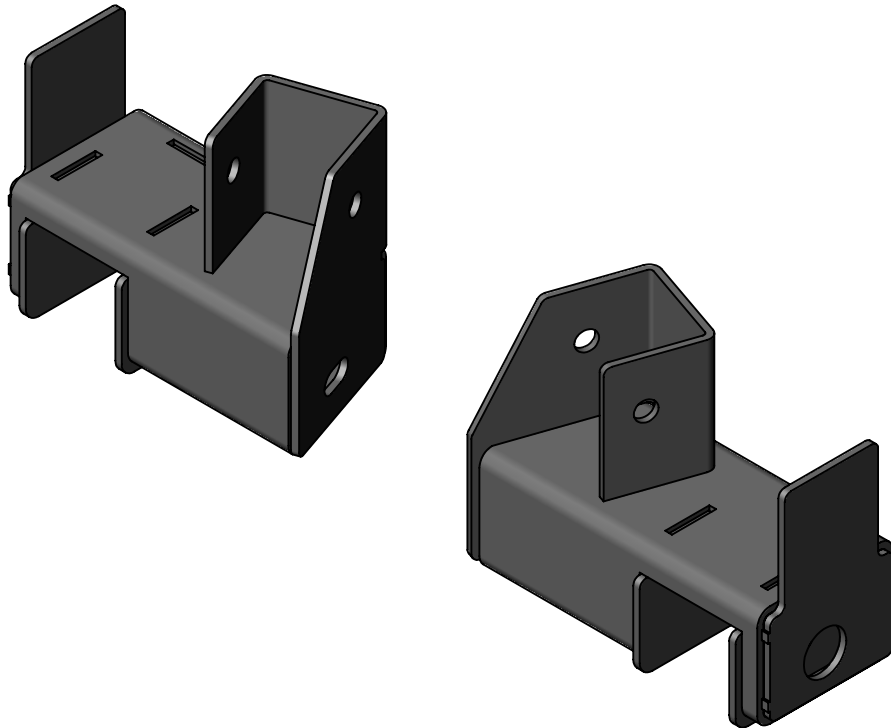

NOTES: This product requires general welding, fabrication and automotive mechanic skills. Welding should only be done by a competent welder. Clayton Off Road implies no guarantees or warranties and is not liable for improper installation. Some grinding and fitment may be required when installing this product. Every vehicle varies slightly and some fabrication may be required. For more information please visit our web site.

Refer to drawing views.

Step 1: Install part number COR-2104310 or COR-2104610 3 piece cross member.

Step 2: Clean frame for welding.

Step 3: Locate brackets according to dimensions given. Wood blocks and a bottle jack work well for holding the brackets in place.

Step 4: Check fitment of ZJ uni-body sub frame rails. Leaving about 1/8" gap is helpful during the install.

Step 5: Tack weld 4 corners of brackets.

Step 6: Weld around all 4 sides of the bracket.

Step 7: Paint frame brackets.

Note: It is possible to use these brackets without part number COR-2104310 or COR-2104610 and measure from the stock cross member. We recommend using part number COR-2204210 to reinforce the brackets.

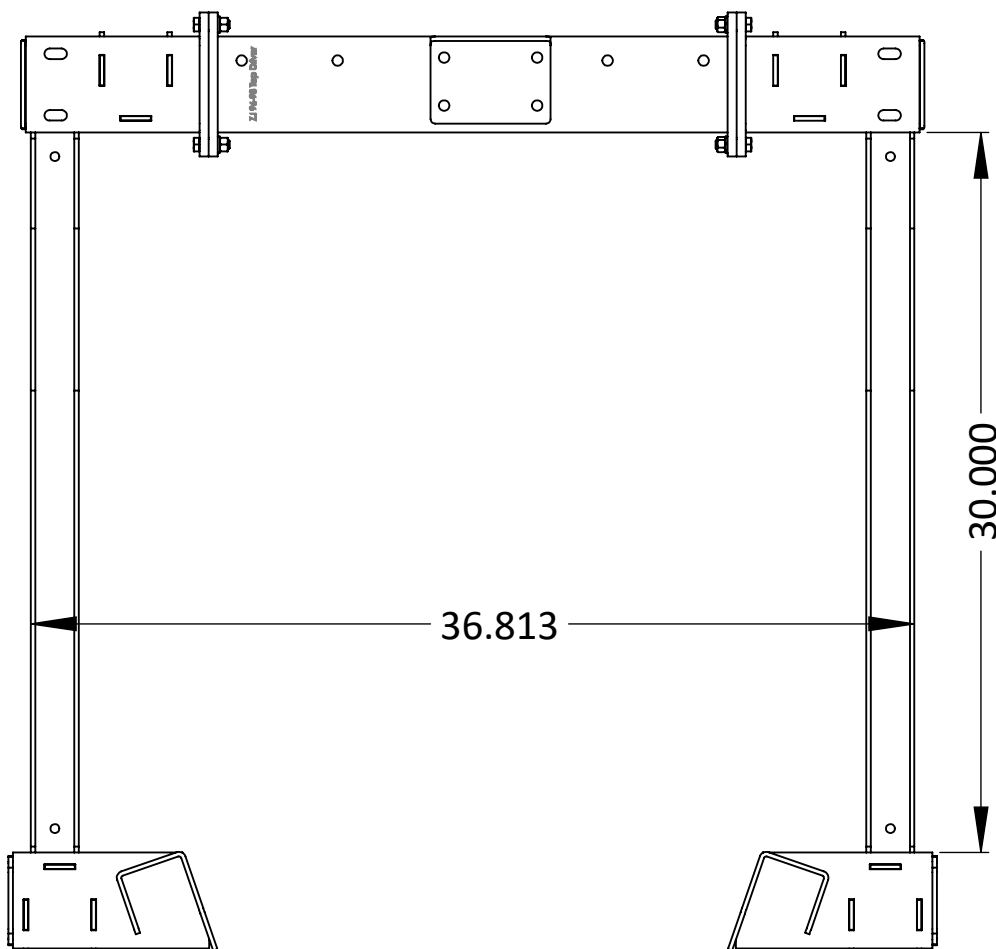

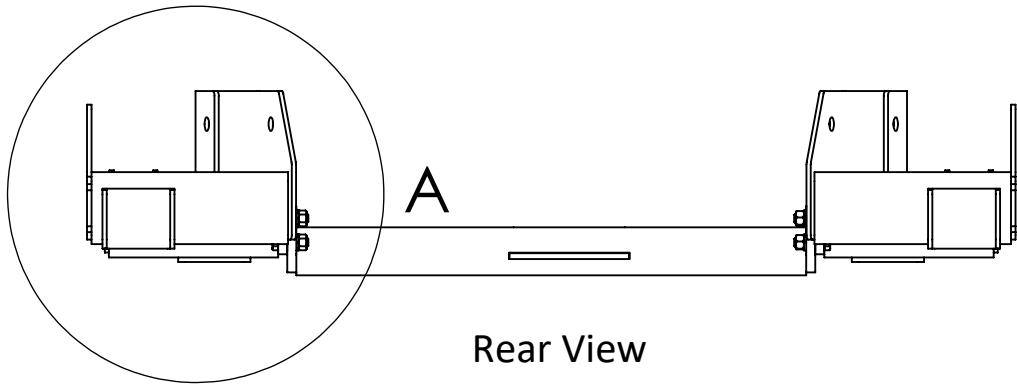

Align edge of
bracket with frame

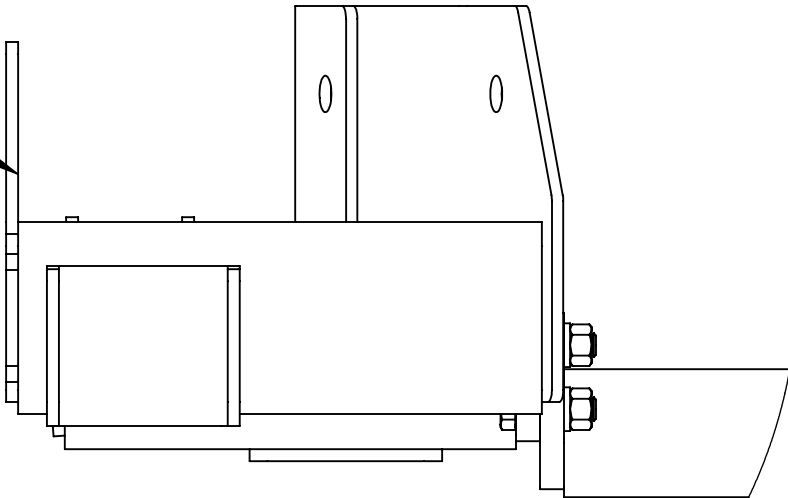

DETAIL A

SCALE 1 : 3

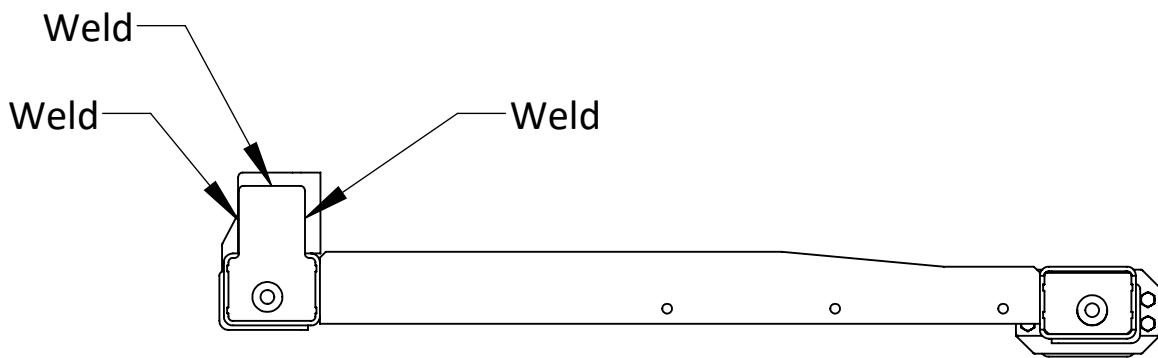
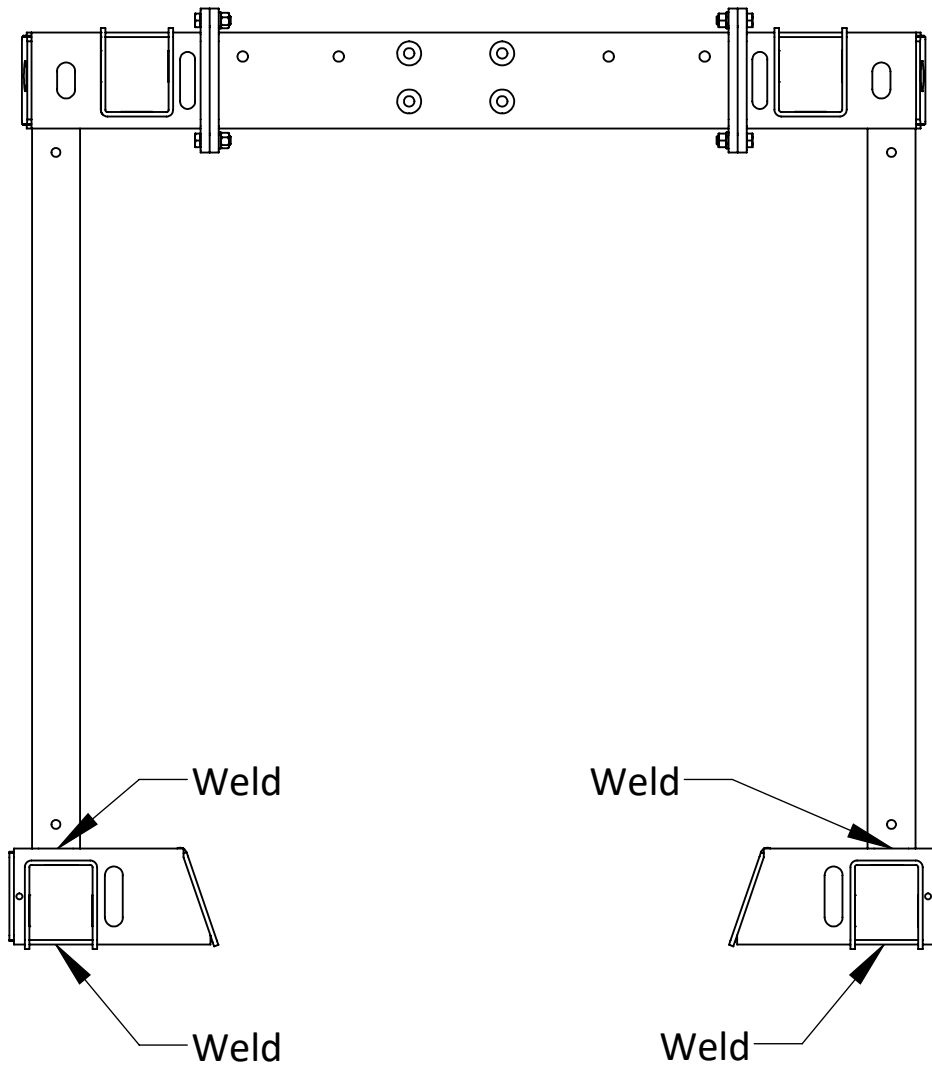

**CLAYTON OFF ROAD
COR-2204210
JEEP GRAND CHEROKEE UNI-BODY FRAME RAILS (1993-1998, ZJ)**



NOTES: This product requires general welding, fabrication and automotive mechanic skills. Welding should only be done by a competent welder. Clayton Off Road implies no guarantees or warranties and is not liable for improper installation. Some grinding and fitment may be required when installing this product. Every vehicle varies slightly and some fabrication may be required. For more information please visit our web site.

Refer to drawing views for measurements.

Step 1: Install part number COR-2104310 or COR-2104610 3 piece cross member.

Step 2: Install part number COR-2204110 rear frame brackets.

Step 1: Clean frame for welding.

Step 2: Locate rails according to dimensions given. Wood blocks and a bottle jack work well for holding the rails in place.

Step 3: Check fitment with ZJ 1/4" transfer case skid plate if using.

Step 4: Tack weld 4 corners of rails.

Step 5: Weld around 3 sides of the end of the rails.

Step 6: Weld along the insides and outside of the rails. Min. 6 welds spaced out.

Step 6: Paint sub frame rails.

Note: These frame rails can be installed alone but will interfere with installing other parts of our system in the future.

